

MERCEDES-BENZ
SPRINTER

2026



UPFIT GUIDE



A Clarience Technologies Company

HELPING MOBILE TECHNICIANS WORK MORE EFFECTIVELY BY PROVIDING ORGANIZED STORAGE SOLUTIONS

AT RANGER DESIGN, WE BELIEVE MORE IS POSSIBLE.

We believe work vehicles and the technicians that drive them can become more organized, more efficient, more productive and more profitable. At Ranger Design we're committed to bringing you the products and services that make that possible.

More means helping you choose the right work van for your application, as well as giving you engineering support and expert advice to help design the most efficient work space in your new vehicle.

More also means getting that new van outfitted and on the road faster, so you can start using it for the reason you bought it.

We're committed to bringing you more, because we believe more is possible.

HOW TO BUY

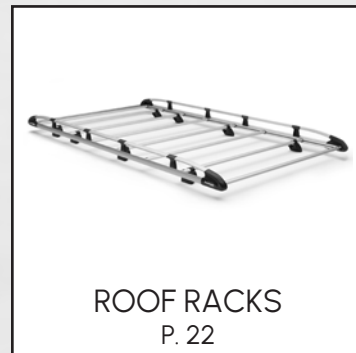
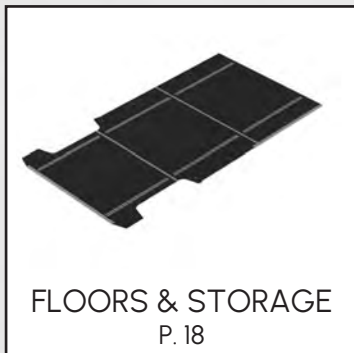
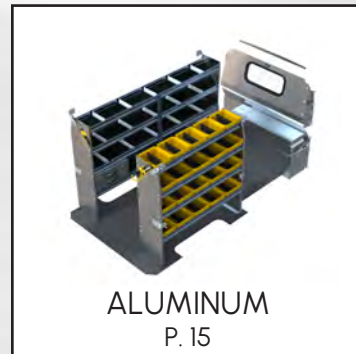
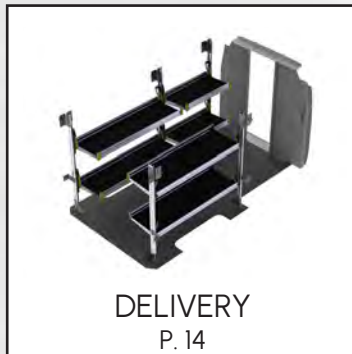
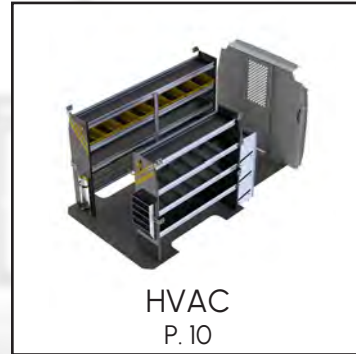
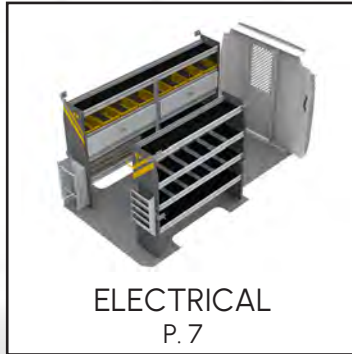

Large Distributor Network Across the Continent

Buy Ranger Design Quickship service is available through your local distributor. rangerdesign.com/find-distributor

Lead Time Quickship orders placed before IPM EST, will ship from our factory within 48 hours.

LAYOUT GUIDES

HOW TO USE THE LAYOUT GUIDE

INSIDE ROOF HEIGHT

To determine the maximum shelf height that can be used in the van.

PARTITION DEPTH

This indicates the space taken up by our partition for this vehicle. Please note that this measurement is determined by the partition that encroaches the most. Some partitions may take up less space. Take note that this measurement may not necessarily be on the floor.

DOOR OPENING

To determine where shelving will land in relation to the door opening. Use this measurement to determine the space available for drawer units.

DIMENSIONS IN RED

These dimensions indicate unique measurements for each wheelbase. Use red dimensions to determine the exact wheelbase of your van.

FLOOR SPACE

This area is usable floor space but due to curvature of the van there may not be the same available area at the roof. Please measure actual van for specific measurement at roof.

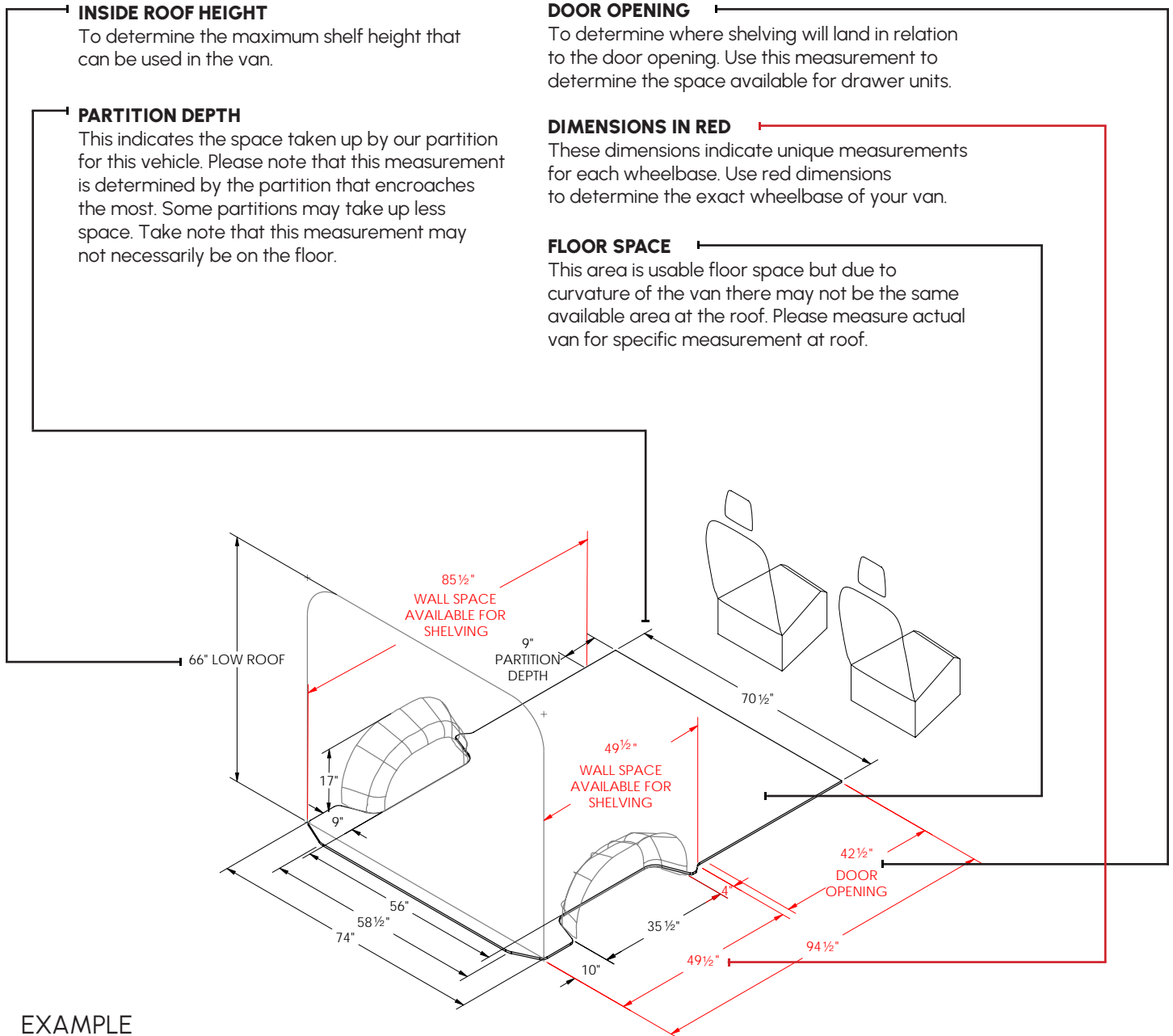

EXAMPLE
LAYOUT GUIDE

GETTING STARTED

MERCEDES-BENZ
SPRINTER
Regular 144" Wheelbase

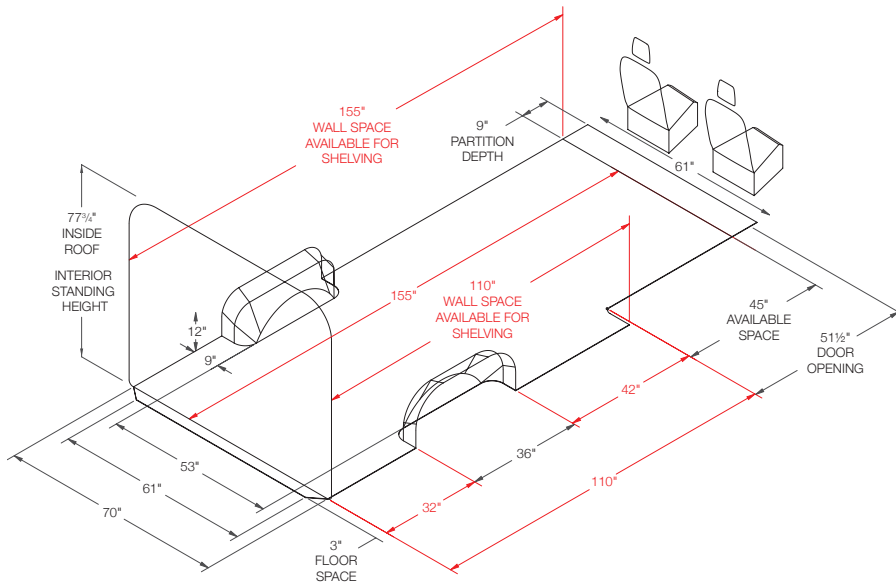
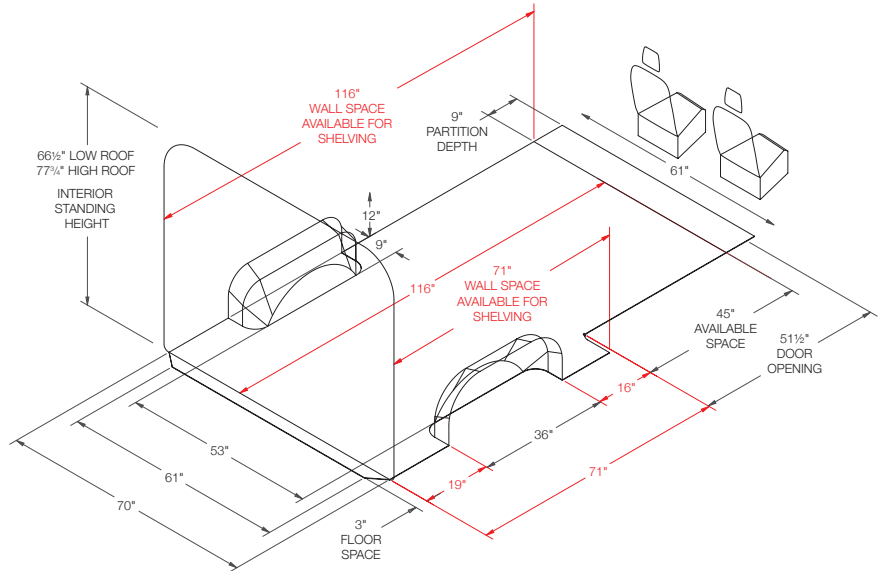

MERCEDES-BENZ
SPRINTER
Long 170" Wheelbase



MERCEDES-BENZ
SPRINTER
170" Extended Wheelbase

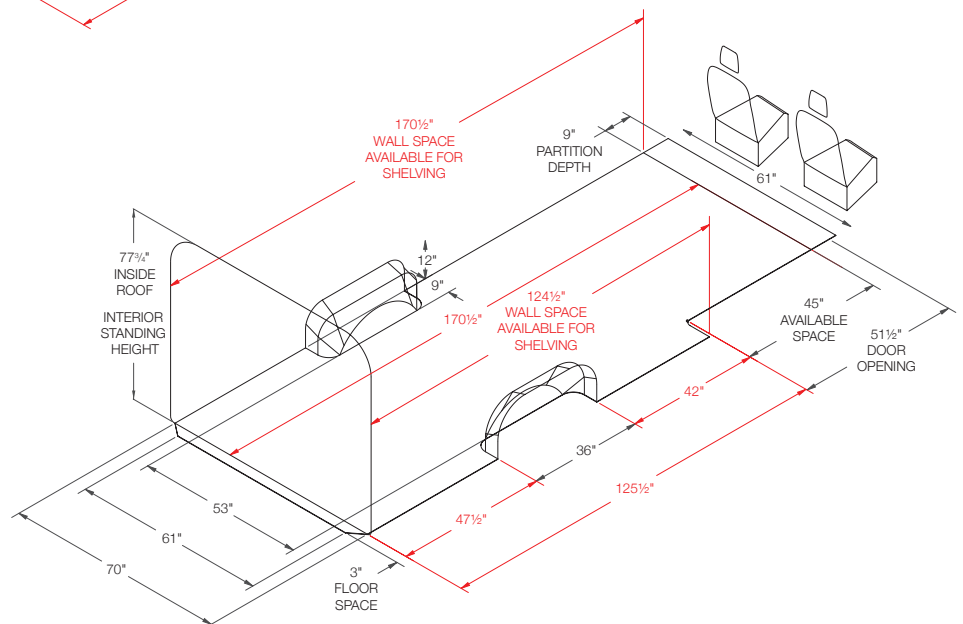

CONTRACTOR PACKAGE

CONTRACTOR

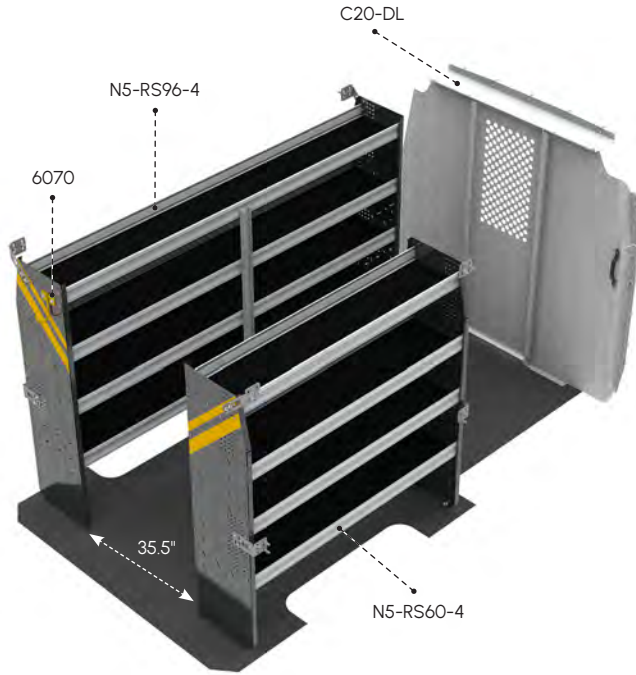

DLS-10 CONTRACTOR

MATERIAL	Steel	WHEELBASE	144"
WEIGHT	291 lbs	ROOF HEIGHT	Low
INSTALL TIME	3.8 hrs	QUICKSHIP	Yes

QTY	PART	DESCRIPTION
1	6070	6" Hook, 3" opening, painted
1	C20-DL	Straight partition with perforated window, no access
1	N5-RS60-4	Steel shelving unit, 14" D x 60" W x 62" H
1	N5-RS96-4	Steel shelving unit, 14" D x 96" W x 62" H

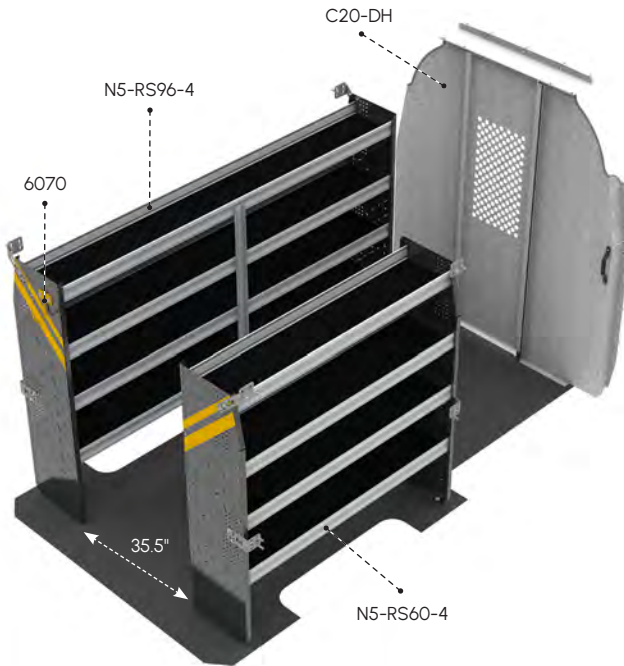

DHS-10 CONTRACTOR

MATERIAL	Steel	WHEELBASE	144"
WEIGHT	300 lbs	ROOF HEIGHT	High
INSTALL TIME	3.8 hrs	QUICKSHIP	Yes

QTY	PART	DESCRIPTION
1	6070	6" Hook, 3" opening, painted
1	C20-DH	Straight partition with perforated window, no access
1	N5-RS60-4	Steel shelving unit, 14" D x 60" W x 62" H
1	N5-RS96-4	Steel shelving unit, 14" D x 96" W x 62" H

VISIT
RANGERDESIGN.COM
TO VIEW OUR
SAFETY PARTITIONS:



CONTRACTOR PACKAGE

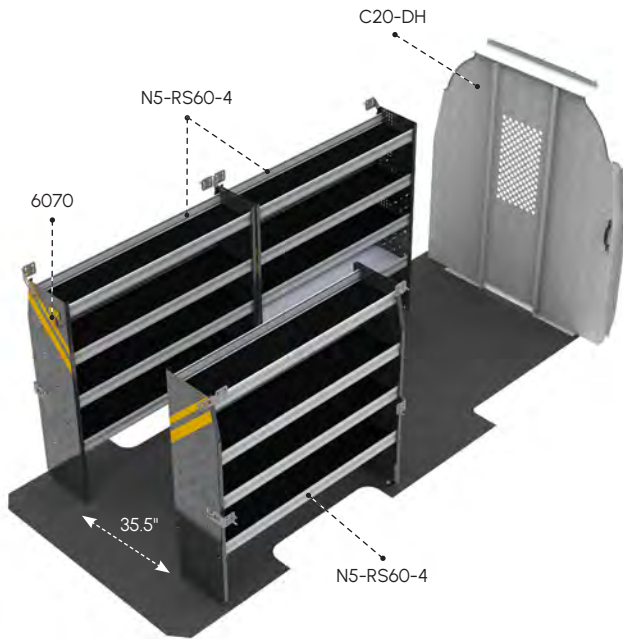

DHL-10 CONTRACTOR

MATERIAL	Steel	WHEELBASE	170", 170" Ext.
WEIGHT	355 lbs	ROOF HEIGHT	High
INSTALL TIME	4.8 hrs	QUICKSHIP	Yes

QTY	PART	DESCRIPTION
1	6070	6" Hook, 3" opening, painted
1	C20-DH	Straight partition with perforated window, no access
3	N5-RS60-4	Steel shelving unit, 14" D x 60" W x 62" H

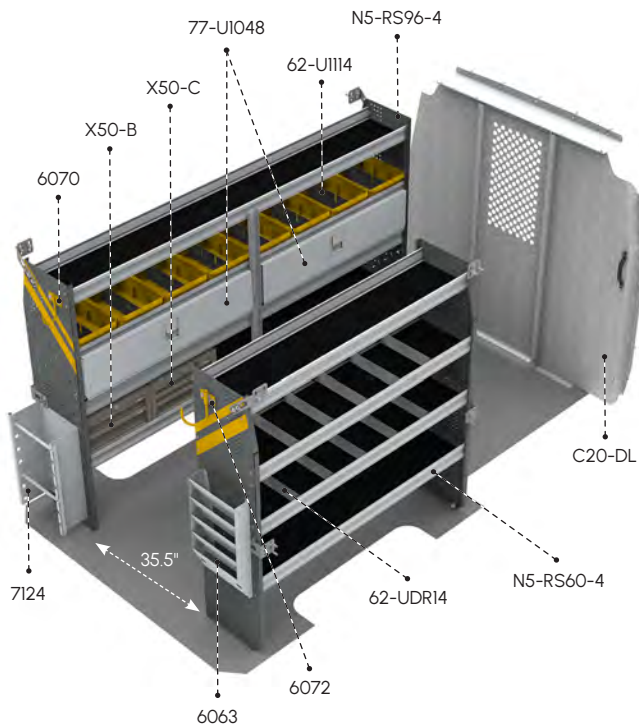

DLS-11 ELECTRICAL

MATERIAL	Steel	WHEELBASE	144"
WEIGHT	404 lbs	ROOF HEIGHT	Low
INSTALL TIME	6.3 hrs	QUICKSHIP	Yes

QTY	PART	DESCRIPTION
1	6063	Paper holder, extra deep, 5 slots
1	6070	6" Hook, 3" opening, painted
1	6072	8" Swivel hook, 4" opening, painted
8	62-U1114	14" Deep plastic bin
2	62-UDR14	Set of 5 dividers for a 14" shelf
1	7124	Reel holder with two 5/8" diameter rods
2	77-U1048	Adjustable shelving door unit - 45" W - for 48" & 96" shelves
1	C20-DL	Straight partition with perforated window, no access
1	N5-RS60-4	Steel shelving unit, 14" D x 60" W x 62" H
1	N5-RS96-4	Steel shelving unit, 14" D x 96" W x 62" H
1	X50-B	Compact 2-drawer unit
1	X50-C	Compact 3-drawer unit

ELECTRICAL PACKAGE

ELECTRICAL

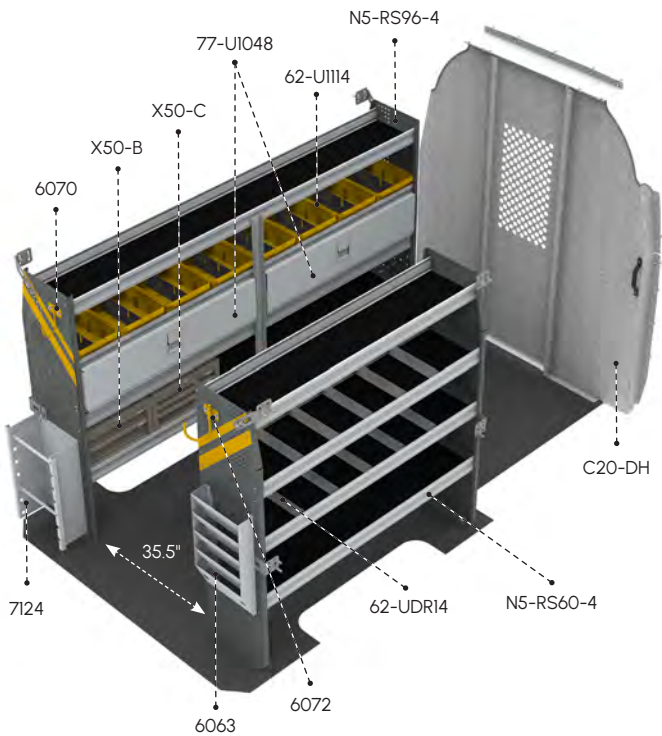

DHS-11 ELECTRICAL

MATERIAL	Steel	WHEELBASE	144"
WEIGHT	413 lbs	ROOF HEIGHT	High
INSTALL TIME	6.3 hrs	QUICKSHIP	Yes

QTY	PART	DESCRIPTION
1	6063	Paper holder, extra deep, 5 slots
1	6070	6" Hook, 3" opening, painted
1	6072	8" Swivel hook, 4" opening, painted
8	62-U1114	14" Deep plastic bin
2	62-UDR14	Set of 5 dividers for a 14" shelf
1	7124	Reel holder with two 5/8" diameter rods
2	77-U1048	Adjustable shelving door unit - 45" W - for 48" & 96" shelves
1	C20-DH	Straight partition with perforated window, no access
1	N5-RS60-4	Steel shelving unit, 14" D x 60" W x 62" H
1	N5-RS96-4	Steel shelving unit, 14" D x 96" W x 62" H
1	X50-B	Compact 2-drawer unit
1	X50-C	Compact 3-drawer unit

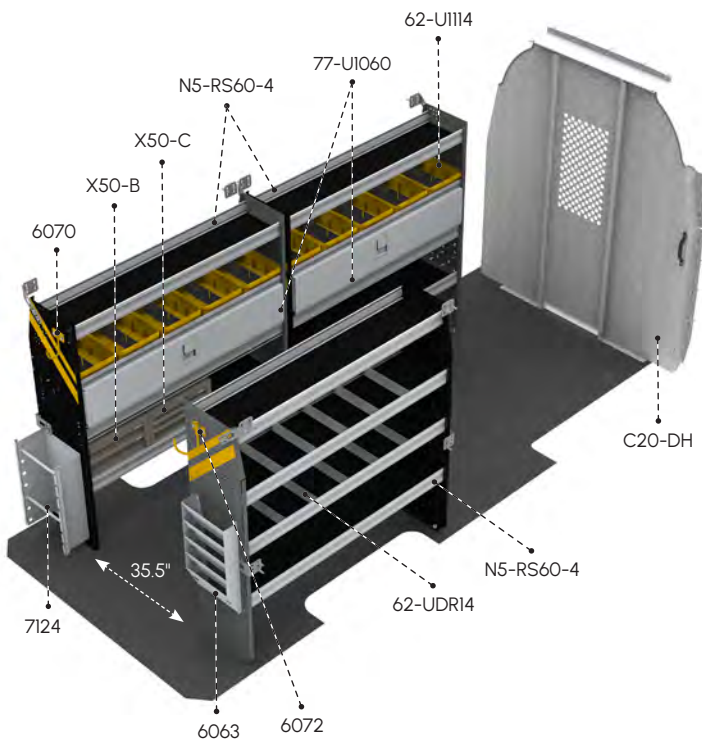

DHL-11 ELECTRICAL

MATERIAL	Steel	WHEELBASE	170", 170" Ext.
WEIGHT	475 lbs	ROOF HEIGHT	High
INSTALL TIME	7.3 hrs	QUICKSHIP	Yes

QTY	PART	DESCRIPTION
1	6063	Paper holder, extra deep, 5 slots
1	6070	6" Hook, 3" opening, painted
1	6072	8" Swivel hook, 4" opening, painted
10	62-U1114	14" Deep plastic bin
2	62-UDR14	Set of 5 dividers for a 14" shelf
1	7124	Reel holder with two 5/8" diameter rods
2	77-U1060	Adjustable shelving door unit - 57" W - for 60" shelves
1	C20-DH	Straight partition with perforated window, no access
3	N5-RS60-4	Steel shelving units, 14" D x 60" W x 62" H
1	X50-B	Compact 2-drawer unit
1	X50-C	Compact 3-drawer unit

ELECTRICAL PACKAGE

ELECTRICAL

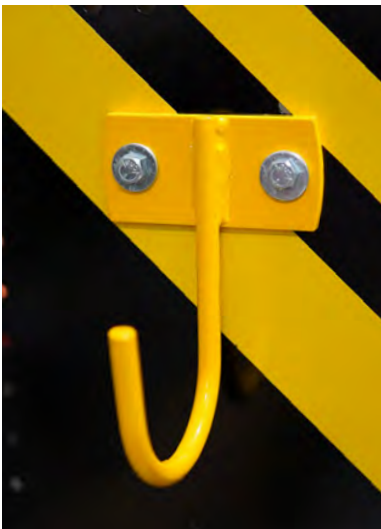

6070
6" Hook, 3" opening, painted

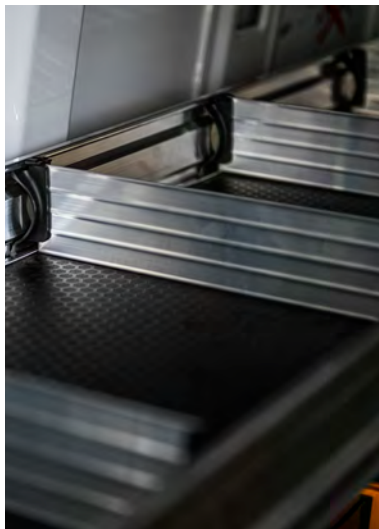

62-UDR14
Set of 5 Dividers for a 14" shelf

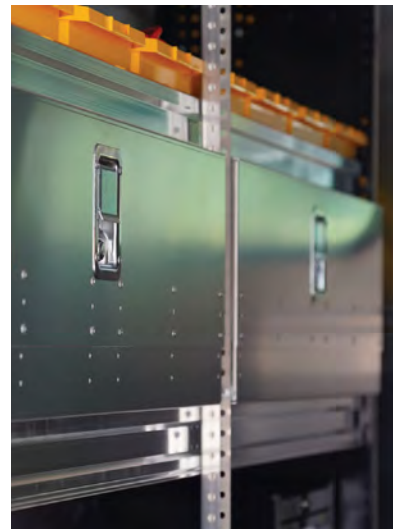

77-U1060
Adjustable Shelving Doors

HVAC PACKAGE

HVAC

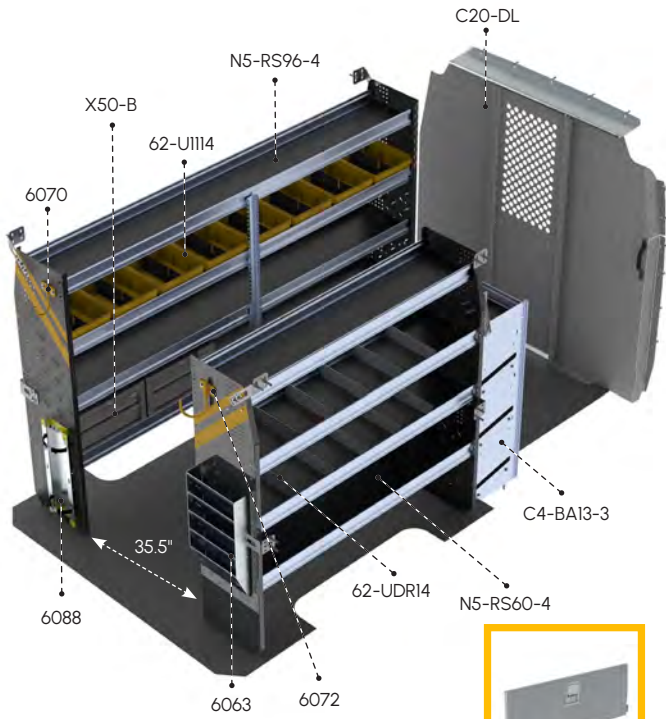

77-U1060

DLS-12

HVAC

MATERIAL	Steel	WHEELBASE	144"
WEIGHT	392 lbs	ROOF HEIGHT	Low
INSTALL TIME	6.1 hrs	QUICKSHIP	Yes

QTY	PART	DESCRIPTION
1	C4-BA13-3	3-Tier refrigerant rack for large bottles
1	6063	Paper holder, extra deep, 5 slots
1	6070	6" Hook, 3" opening, painted
1	6072	8" Swivel hook, 4" opening, painted
1	6088	Large aluminum bottle holder, with two black nylon straps
8	62-U1114	14" Deep plastic bin
2	62-UDR14	Set of 5 dividers for a 14" shelf
1	77-U1060	Adjustable shelving door unit - 57" W - for 60" shelves
1	C20-DL	Straight partition with perforated window, no access
1	N5-RS60-4	Steel shelving unit, 14" D x 60" W x 62" H
1	N5-RS96-4	Steel shelving unit, 14" D x 96" W x 62" H
2	X50-B	Compact 2-drawer unit

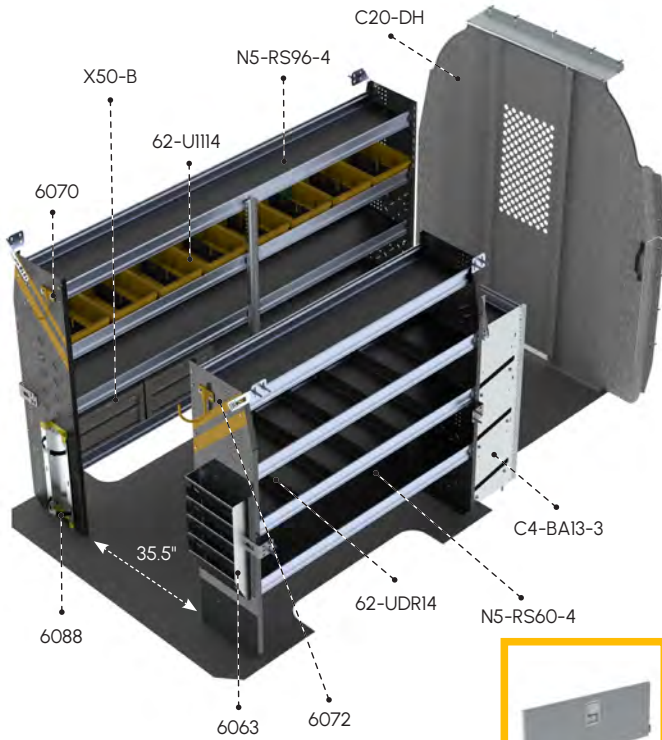

77-U1060

DHS-12

HVAC

MATERIAL	Steel	WHEELBASE	144"
WEIGHT	401 lbs	ROOF HEIGHT	High
INSTALL TIME	6.1 hrs	QUICKSHIP	Yes

QTY	PART	DESCRIPTION
1	C4-BA13-3	3-Tier refrigerant rack for large bottles
1	6063	Paper holder, extra deep, 5 slots
1	6070	6" Hook, 3" opening, painted
1	6072	8" Swivel hook, 4" opening, painted
1	6088	Large aluminum bottle holder, with two black nylon straps
8	62-U1114	14" Deep plastic bin
2	62-UDR14	Set of 5 dividers for a 14" shelf
1	77-U1060	Adjustable shelving door unit - 57" W - for 60" shelves
1	C20-DH	Straight partition with perforated window, no access
1	N5-RS60-4	Steel shelving unit, 14" D x 60" W x 62" H
1	N5-RS96-4	Steel shelving unit, 14" D x 96" W x 62" H
2	X50-B	Compact 2-drawer unit

HVAC PACKAGE

DHL-12 HVAC

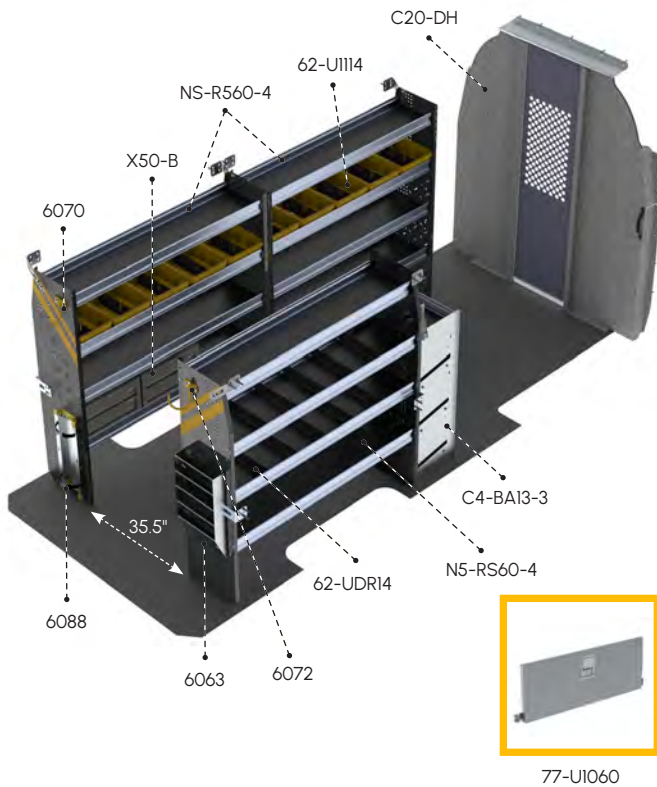

MATERIAL	Steel	WHEELBASE	170", 170 Ext.
WEIGHT	460 lbs	ROOF HEIGHT	High
INSTALL TIME	7.1 hrs	QUICKSHIP	Yes

QTY	PART	DESCRIPTION
1	C4-BA13-3	3-Tier refrigerant rack for large bottles
1	6063	Paper holder, extra deep, 5 slots
1	6070	6" Hook, 3" opening, painted
1	6072	8" Swivel hook, 4" opening, painted
1	6088	Large aluminum bottle holder, with two black nylon straps
10	62-U1114	14" Deep plastic bin
2	62-UDR14	Set of 5 dividers for a 14" shelf
1	77-UI060	Adjustable shelving door unit - 57" W - for 60" shelves
1	C20-DH	Straight partition with perforated window, no access
3	N5-RS60-4	Steel shelving units, 14" D x 60" W x 62" H
2	X50-B	Compact 2-drawer unit



77-UI060

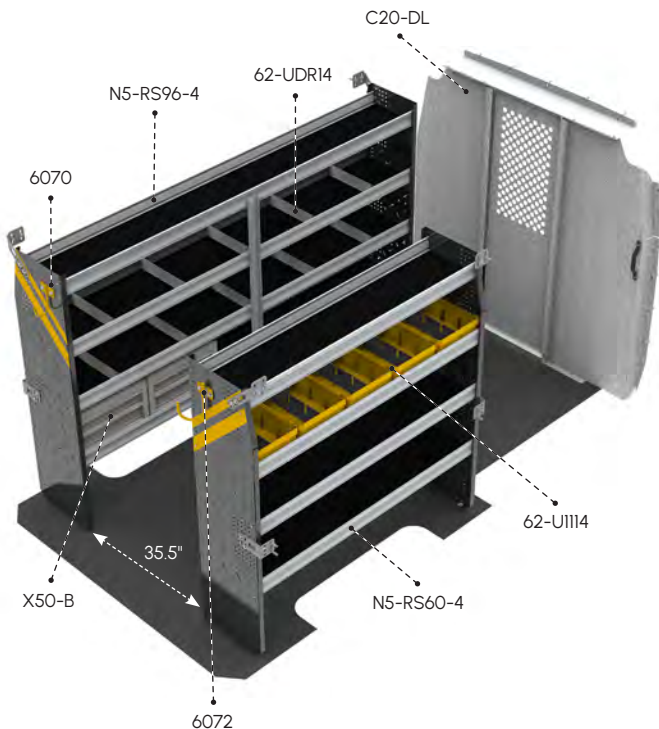

DLS-16 SERVICE

MATERIAL	Steel	WHEELBASE	144"
WEIGHT	361 lbs	ROOF HEIGHT	Low
INSTALL TIME	4.6 hrs	QUICKSHIP	Yes

QTY	PART	DESCRIPTION
1	6070	6" Hook, 3" opening, painted
1	6072	8" Swivel hook, 4" opening, painted
5	62-U1114	14" Deep plastic bin
2	62-UDR14	Set of 5 dividers for a 14" shelf
1	C20-DL	Straight partition with perforated window, no access
1	N5-RS60-4	Steel shelving unit, 14" D x 60" W x 62" H
1	N5-RS96-4	Steel shelving unit, 14" D x 96" W x 62" H
2	X50-B	Compact 2-drawer unit

HVAC

SERVICE PACKAGE

SERVICE

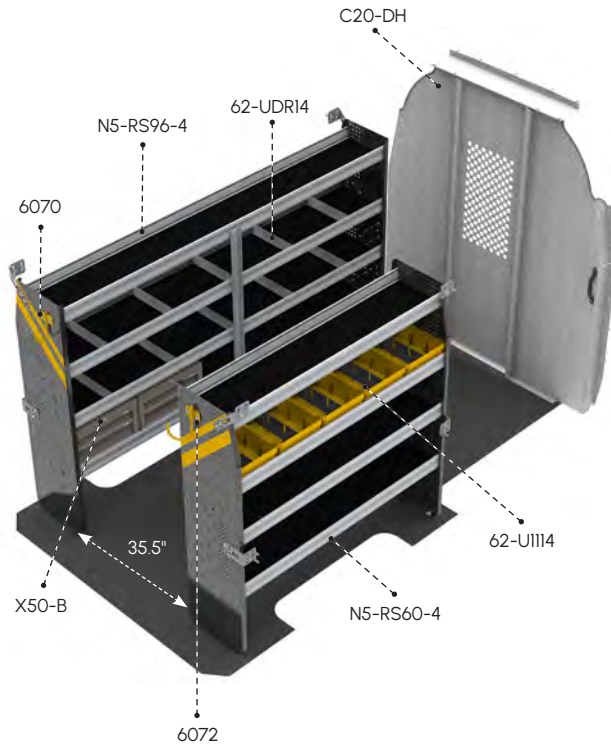

DHS-16 SERVICE

MATERIAL	Steel	WHEELBASE	144"
WEIGHT	370 lbs	ROOF HEIGHT	High
INSTALL TIME	4.6 hrs	QUICKSHIP	Yes

QTY	PART	DESCRIPTION
1	6070	6" Hook, 3" opening, painted
1	6072	8" Swivel hook, 4" opening, painted
5	62-U1114	14" Deep plastic bin
2	62-UDR14	Set of 5 dividers for a 14" shelf
1	C20-DH	Straight partition with perforated window, no access
1	N5-RS60-4	Steel shelving unit, 14" D x 60" W x 62" H
1	N5-RS96-4	Steel shelving unit, 14" D x 96" W x 62" H
2	X50-B	Compact 2-drawer unit

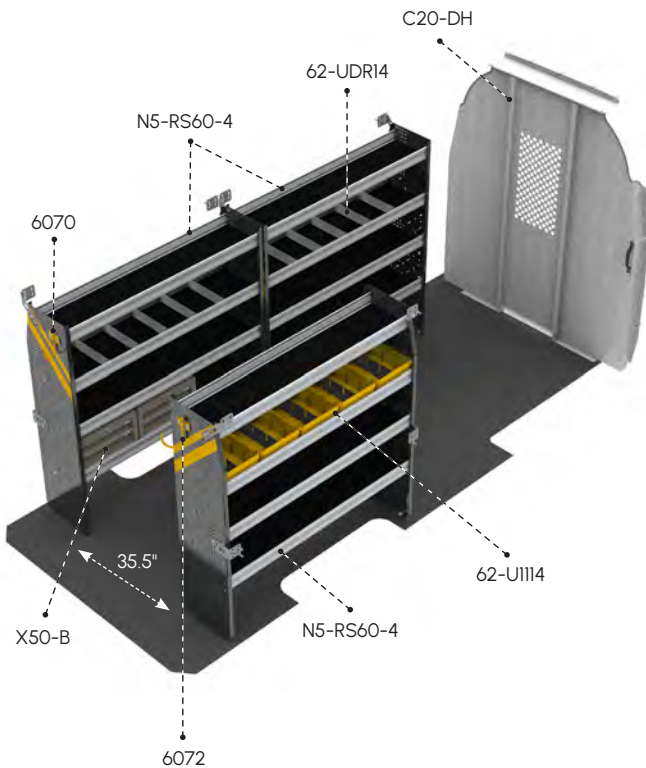

DHL-16 SERVICE

MATERIAL	Steel	WHEELBASE	170", 170" Ext.
WEIGHT	425 lbs	ROOF HEIGHT	High
INSTALL TIME	5.6 hrs	QUICKSHIP	Yes

QTY	PART	DESCRIPTION
1	6070	6" Hook, 3" opening, painted
1	6072	8" Swivel hook, 4" opening, painted
5	62-U1114	14" Deep plastic bin
2	62-UDR14	Set of 5 dividers for a 14" shelf
1	C20-DH	Straight partition with perforated window, no access
3	N5-RS60-4	Steel shelving unit, 14" D x 60" W x 62" H
2	X50-B	Compact 2-drawer unit

SERVICE PACKAGE



SERVICE



62-U114
14" Deep Plastic Bins



6072
8" Swivel Hook



X50-B
Compact 2-Drawer unit

DELIVERY PACKAGE

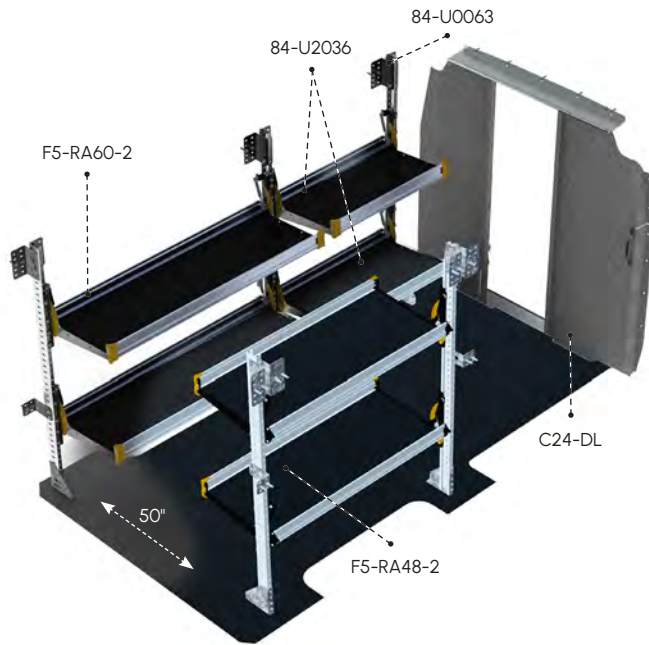

DLS-19 DELIVERY

MATERIAL	Aluminum	WHEELBASE	144"
WEIGHT	273 lbs	ROOF HEIGHT	Low
INSTALL TIME	5.3 hrs	QUICKSHIP	Yes

QTY	PART	DESCRIPTION
1	C24-DL	Straight walk-through steel partition
1	84-U0063	Post assembly for fold-away shelving, 63"
2	84-U2036	Fold-away shelf tray, 20" D x 36" W
1	F5-RA48-2	Fold-away unit, 2 levels, 25" D x 48" W x 63" H
1	F5-RA60-2	Fold-away unit, 2 levels, 25" D x 60" W x 63" H

DELIVERY

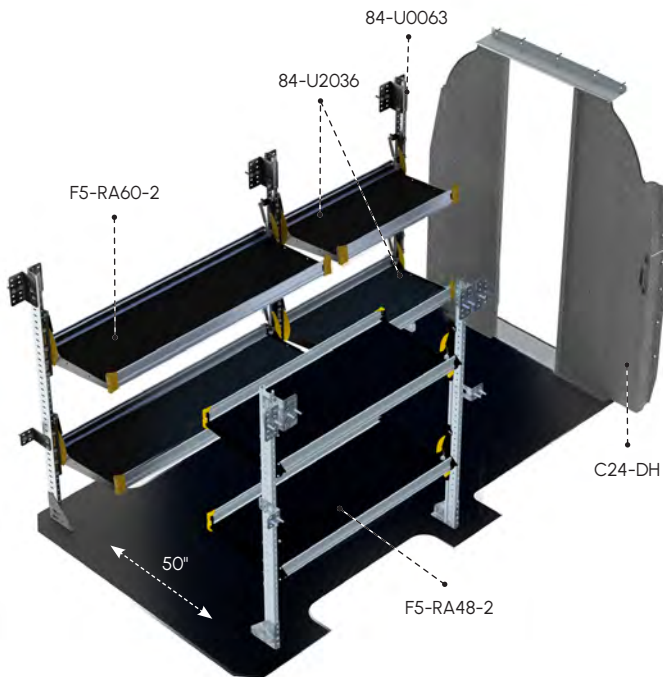

DHS-19 DELIVERY

MATERIAL	Aluminum	WHEELBASE	144"
WEIGHT	278 lbs	ROOF HEIGHT	High
INSTALL TIME	5.3 hrs	QUICKSHIP	Yes

QTY	PART	DESCRIPTION
1	C24-DH	Straight walk-through steel partition
1	84-U0063	Post assembly for fold-away shelving, 63"
2	84-U2036	Fold-away shelf tray, 20" D x 36" W
1	F5-RA48-2	Fold-away unit, 2 levels, 25" D x 48" W x 63" H
1	F5-RA60-2	Fold-away unit, 2 levels, 25" D x 60" W x 63" H

DELIVERY PACKAGE

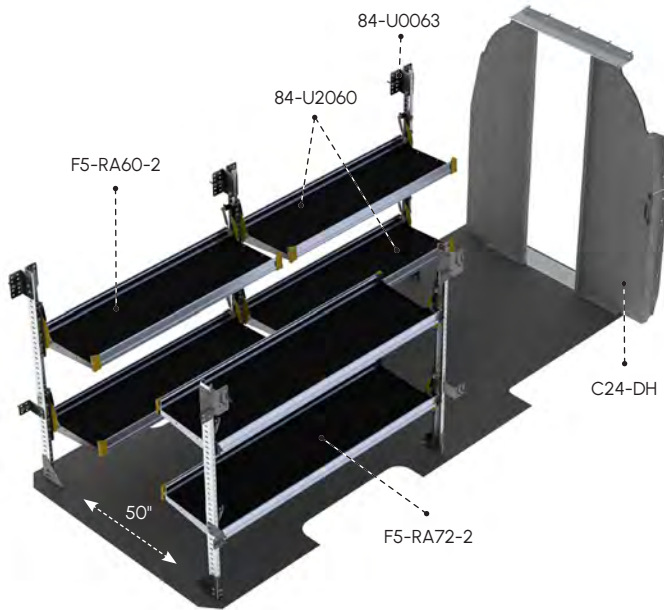

DHL-19 DELIVERY

MATERIAL	Aluminum	WHEELBASE	170", 170" Ext.
WEIGHT	298 lbs	ROOF HEIGHT	High
INSTALL TIME	5.3 hrs	QUICKSHIP	Yes

QTY	PART	DESCRIPTION
1	C24-DH	Straight walk-through steel partition
1	F5-RA60-2	Fold-away unit, 2 levels, 60" W x 63" H
1	84-U0063	Post assembly for fold-away shelving, 63"
2	84-U2060	Fold-away shelf tray, 20" D x 60" W
1	F5-RA72-2	Fold-away unit, 2 levels, 72" W x 63" H

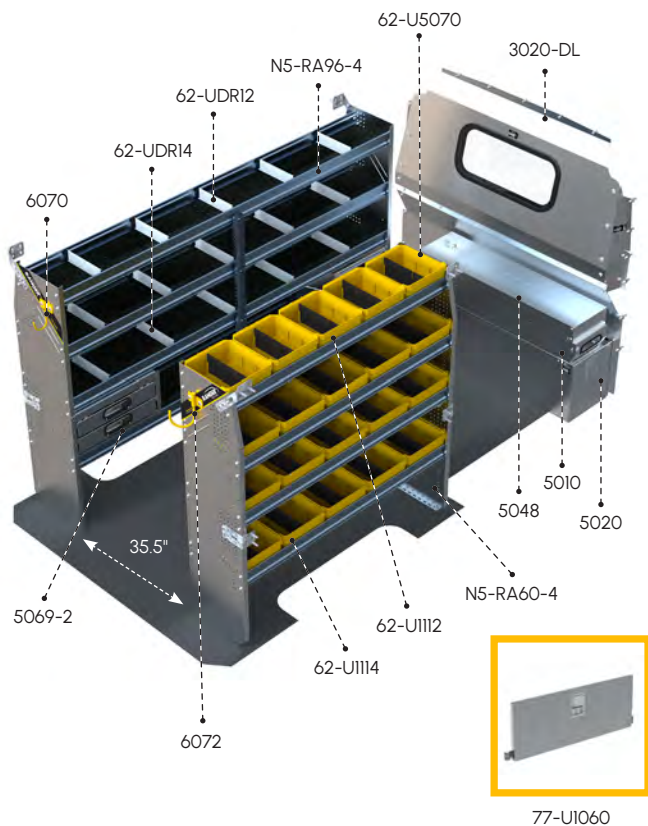

DLS-27 ALUMINUM

MATERIAL	Aluminum	WHEELBASE	144"
WEIGHT	404 lbs	ROOF HEIGHT	Low
INSTALL TIME	7.5 hrs	QUICKSHIP	Yes

QTY	PART	DESCRIPTION
1	3020-DL	Contoured safety partition with glass window
1	5010	Partslider drawer
1	5020	Tool drawer 48" D x 14" W x 16" H
1	5048	Top edge
1	5069-2	2-Drawer cabinet
2	62-U5070	Partskeeper carry case with holder
1	6070	6" Hook, 3" opening, painted
1	6072	8" Swivel hook, 4" opening, painted
5	62-U1112	12" Deep plastic bin
15	62-U1114	14" Deep plastic bin
1	62-UDR12	Set of 5 dividers for a 12" shelf
2	62-UDR14	Set of 5 dividers for a 14" shelf
1	77-U1060	Adjustable shelving door unit - 57" W - for 60" shelves
1	N5-RA60-4	Aluminum shelving unit, 60", 14"D x 60" W x 62"H
1	N5-RA96-4	Aluminum shelving unit, 96", 14"D x 96" W x 62"H

ALUMINUM PACKAGE

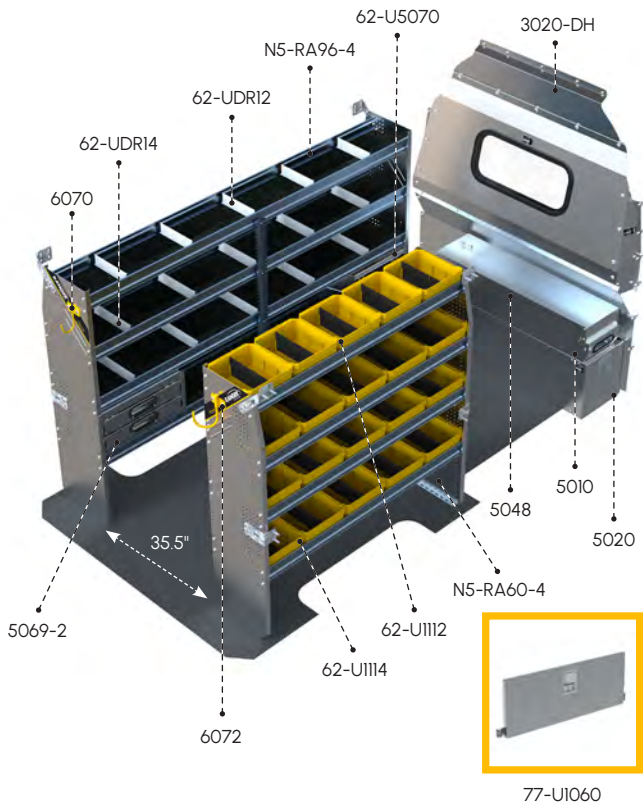

DHS-27 ALUMINUM

MATERIAL	Aluminum	WHEELBASE	144"
WEIGHT	411 lbs	ROOF HEIGHT	High
INSTALL TIME	7.5 hrs	QUICKSHIP	Yes

QTY	PART	DESCRIPTION
1	3020-DH	Contoured safety partition with glass window
1	5010	Partslider drawer
1	5020	Tool drawer 48" D x 14" W x 16" H
1	5048	Top edge
1	5069-2	2-Drawer cabinet
2	62-U5070	Partskeeper carry case with holder
1	6070	6" Hook, 3" opening, painted
1	6072	8" Swivel hook, 4" opening, painted
5	62-U1112	12" Deep plastic bin
15	62-U1114	14" Deep plastic bin
1	62-UDR12	Set of 5 dividers for a 12" shelf
2	62-UDR14	Set of 5 dividers for a 14" shelf
1	77-U1060	Adjustable shelving door unit - 57" W - for 60" shelves
1	N5-RA60-4	Aluminum shelving unit, 60", 14"D x 60" W x 62"H
1	N5-RA96-4	Aluminum shelving unit, 96", 14"D x 96" W x 62"H

DHL-27 ALUMINUM

MATERIAL	Aluminum	WHEELBASE	170", 170" Ext.
WEIGHT	445 lbs	ROOF HEIGHT	High
INSTALL TIME	8.5 hrs	QUICKSHIP	Yes

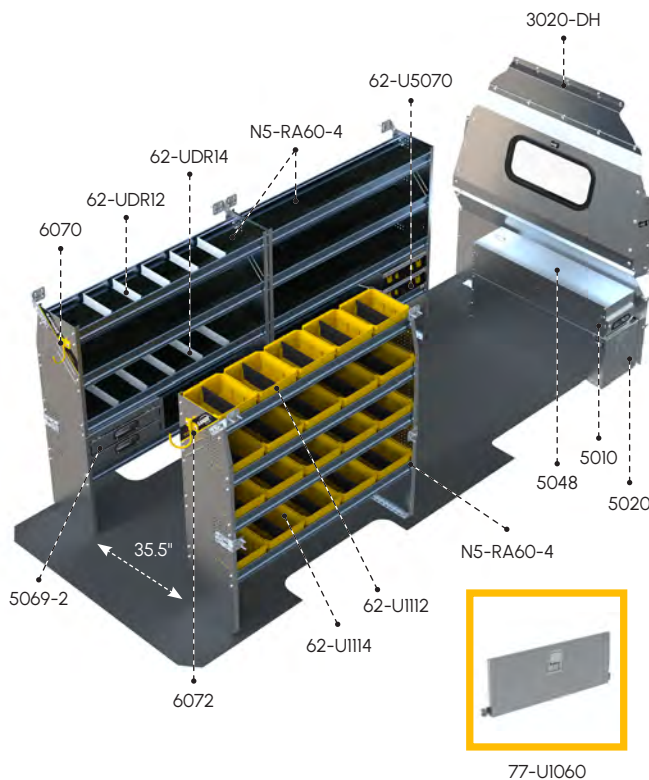

QTY	PART	DESCRIPTION
1	3020-DH	Contoured safety partition with glass window
1	5010	Partslider 48" D
1	5020	Tool drawer 48" D x 14" W x 16" H
1	5048	Top edge
1	5069-2	2-Drawer cabinet
2	62-U5070	Partskeeper carry case with holder
1	6070	6" Hook, 3" opening, painted
1	6072	8" Swivel hook, 4" opening, painted
5	62-U1112	12" Deep plastic bin
15	62-U1114	14" Deep plastic bin
1	62-UDR12	Set of 5 dividers for a 12" shelf
2	62-UDR14	Set of 5 dividers for a 14" shelf
1	77-U1060	Adjustable shelving door unit - 57" W - for 60" shelves
3	N5-RA60-4	Aluminum shelving unit, 60", 14"D x 60" W x 62"H

ALUMINUM PACKAGE



N5-RA60-4
Aluminum shelving unit



5010, 5020, 5048
Tool Drawer Stack



62-U5070
Partskeeper Carry Cases

E-FLOORS

Easy. Efficient. EV Ready. Compatible with both electric and gas powered vehicles.



6541-DR

Mercedes-Benz Sprinter E-Floor

MARINE-GRADE PLYWOOD	
WHEELBASE	144"
WEIGHT	82 lbs



6541-DL

Mercedes-Benz Sprinter E-Floor

MARINE-GRADE PLYWOOD	
WHEELBASE	170"
WEIGHT	112 lbs



6541-DX

Mercedes-Benz Sprinter E-Floor

MARINE-GRADE PLYWOOD	
WHEELBASE	170" Ext.
WEIGHT	122 lbs

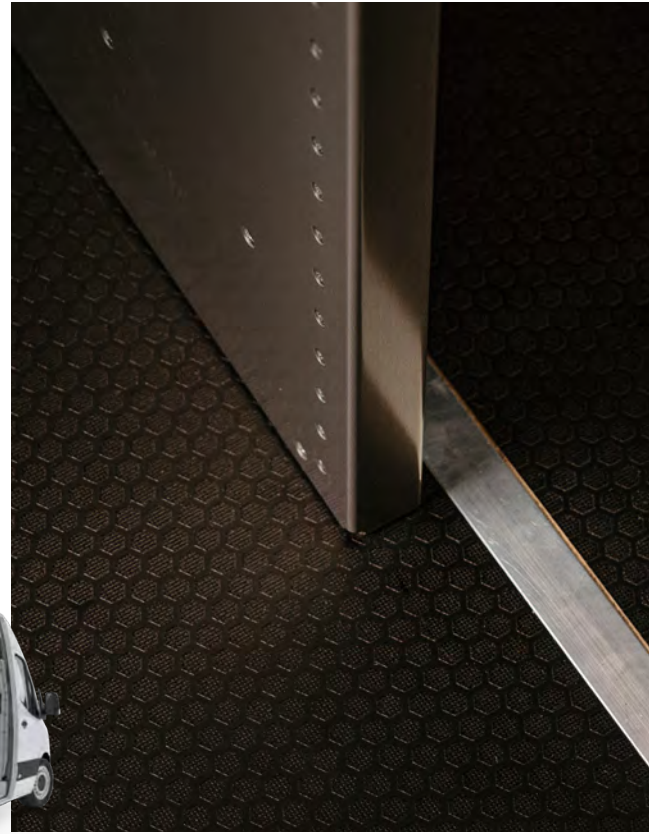

SPRINTER E-FLOOR

DRAWERS

Increase storage and organization with Ranger Design's line of drawer units.

FLOORS



5010

Partslider drawer

ALUMINUM	
DIMENSIONS	48" D x 12" W x 6" H
WEIGHT CAPACITY	150 lbs
WEIGHT	25 lbs



5020

Tool drawer

ALUMINUM	
DIMENSIONS	48" D x 14" W x 16" H
WEIGHT CAPACITY	320 lbs
WEIGHT	70 lbs



5048

Top edge, for 5010 Partslider

ALUMINUM	
DIMENSIONS	48" D x 12" W x 4" H
WEIGHT CAPACITY	—
WEIGHT	8 lbs



TOOL DRAWER TIP: Stack these drawers for maximum efficiency

STORAGE UNITS

Ergonomic storage solutions for the cargo space in your vehicle.



CABINET FOR MILWAUKEE ORGANIZERS



62-U5076

Shelf Mount for Milwaukee Organizers and Toolboxes

ALUMINUM	
DIMENSIONS	3.3" D × 22.8" W × 14.7" H
WEIGHT	3.6 lbs



C5-MA20-6

2-Shelf Cabinet for Milwaukee Packout Organizers

ALUMINUM	
DIMENSIONS	14.9" D × 21.8" W × 62" H
WEIGHT	40 lbs



C5-PA18-8

Partskeeper Cabinet with 8 Carry Cases and 2 shelves

ALUMINUM	
DIMENSIONS	14" D × 19" W × 62" H
WEIGHT	68 lbs



N5-PS20-8

Partskeeper Cabinet with 8 Carry Cases and 2 shelves

STEEL	
DIMENSIONS	16" D × 20" W × 62" H
WEIGHT	89 lbs



N5-LA16-1

Locker with top shelf and 2 hooks

ALUMINUM	
DIMENSIONS	16" D × 14" W × 62" H
WEIGHT	41 lbs



N5-LS16-1

Locker with top shelf and 2 hooks

STEEL	
DIMENSIONS	16" D × 14" W × 62" H
WEIGHT	54 lbs

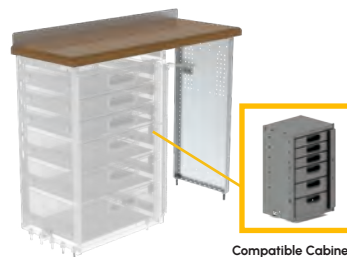

Compatible Cabinets
5060-5, 5060-6, 5060-8
(Sold separately)

S3-WA48-0

Workbench with hardwood top, 1 end-panel

ALUMINUM	
DIMENSIONS	18" D × 48" W × 40" H
WEIGHT	49 lbs



S3-WA48-1

Workbench with hardwood top and shelf tray

ALUMINUM	
DIMENSIONS	18" D × 48" W × 40" H
WEIGHT	66 lbs

STORAGE UNITS

ACCESSORIES

Choose the finishing details to tailor the upfit to your specific needs.

CARGO HOLDERS

Keep your equipment organized with a dedicated storage spot. No more loose reels or cans on the floor. Everything stays secure and easy to reach.



6057

Can Holder

ALUMINUM	
DIMENSIONS	3" D × 8.5" W × 3" H
WEIGHT	1 lb



6061

2-Slot Paper Holder, extra deep

ALUMINUM	
DIMENSIONS	3.75" D × 12.75" W × 12" H
WEIGHT	2 lbs



6063

5-Slot Paper Holder, extra deep

ALUMINUM	
DIMENSIONS	3.75" D × 12.75" W × 24" H
WEIGHT	7 lbs



6068

Wire Hard Hat Holder

STEEL	
DIMENSIONS	—
WEIGHT	1 lb



7124

Reel Holder, two 5/8" rods

ALUMINUM	
DIMENSIONS	7.25" D × 15" W × 24" H
WEIGHT	11 lbs



5-SLOT PAPER HOLDER ON STEEL SHELF UNIT

STORAGE HOOKS

Keep frequently used items such as hats, vests and extension cords hanging within easy reach in your vehicle.



6070

6" Hook, 3" opening

STEEL	
DIMENSIONS	3" D
WEIGHT	2 lbs



6071

Triple 6" Hook, 3" opening

STEEL	
DIMENSIONS	4" D
WEIGHT	1 lbs



6073

Large Movable Hook

ALUMINUM	
DIMENSIONS	6.5" D × 2.75" W × 4" H
WEIGHT	1 lb

DRIVER SAFETY

Enhance road safety with accessories that improve visibility, ventilation, and overall awareness. From improved airflow to increased visibility, these features help create a safe driving environment.

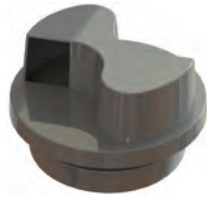

6050

Flettner Vent, rotary design (4" H above and 1.4" H below)

PLASTIC	
DIAMETER	8.88"
WEIGHT	2 lbs



6082

Triangle Kit and Holder with 3 triangles

ALUMINUM	
DIMENSIONS	5.2" D x 6.4" W x 21.5" H
WEIGHT	15 lb



6090

Back up Alarm, die cast housing, encapsulated circuitry

OTHER	
DIMENSIONS	—
WEIGHT	1 lbs

LED LIGHTING

Keeps the cargo space bright and visible, no matter what time of day or night. Eliminate any chance of injury when searching through your tools in the dark.

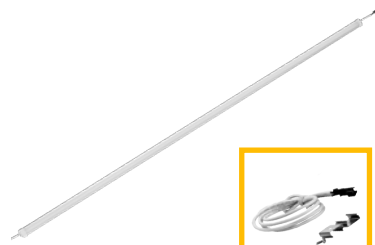

6092-42

Universal LED Light Kit for vans (12V DC / 1200 Lm / 10W)

OTHER	
DIMENSIONS	42" L x 1" H
WEIGHT	1 lb

GRAB HANDLE

Install a Grab Handle for maximum support and stability when climbing into your van. Grab Handles can also act as tie downs for extra cargo during transport.



6093-27

Large Grab Handle

STEEL	
DIMENSIONS	1.8" W x 30" H x 3.5" D
WEIGHT	3 lbs



REAR MAX STEP

Climbing in and out of your van several times a day can put a strain on your legs and back. The Max Step gives tradespeople quick and easy access to their cargo space without the effort.

6550-DS

Max Step for the Mercedes-Benz Sprinter

STEEL	
DIMENSIONS	21" D x 56" W x 2.5" H
WEIGHT	36 lbs



VISIT OUR WEBSITE TO VIEW MORE ACCESSORIES

ROOF RACKS

Increase efficiency with the right roof rack for your job.



CARGO+ RACK

ALUMINUM			
PART	WHEELBASE	ROOF HEIGHT	LADDER LENGTH
1506-DS	144"	Standard	-
1506-DH	170", 170" Ext	High	-



CARGO RACK

ALUMINUM			
PART	WHEELBASE	ROOF HEIGHT	LADDER LENGTH
1605-DH	144", 170", 170" Ext	Standard / High	-
1605-DH3	144", 170", 170" Ext	Standard / High	-



COMBINATION RACK

ALUMINUM			
PART	WHEELBASE	ROOF HEIGHT	LADDER LENGTH
1625-DH	144", 170", 170" Ext	Standard / High	32 ft



DOUBLE CLAMP RACK

ALUMINUM			
PART	WHEELBASE	ROOF HEIGHT	LADDER LENGTH
1630-DH	144", 170", 170" Ext	Standard / High	32 ft
1630-DH3	144", 170", 170" Ext	Standard / High	32 ft



MAX RACK

ALUMINUM			
PART	WHEELBASE	ROOF HEIGHT	LADDER LENGTH
1870-DH	144", 170", 170" Ext	Standard / High	32 ft
1880-DH	144", 170", 170" Ext	Standard / High	32 ft
1880-DH3	144", 170", 170" Ext	Standard / High	32 ft



ACCESS STOW

ALUMINUM			
PART	WHEELBASE	ROOF HEIGHT	LADDER LENGTH
1920-DH	144", 170", 170" Ext	Standard / High	32 ft
1930-DH	144", 170", 170" Ext	Standard / High	32 ft



CHECK OUT OUR REAR ACCESS LADDER BY PRIME DESIGN



TURNKEY FLEET SERVICES



Ship Through or Local Installation Across North America for all Types of Cargo Vans

We are pleased to offer an efficient, personalized service to answer all questions regarding:

1. Analysis

- › Cargo Needs Analysis
- › Custom 3D CAD Layouts
- › Hands-on Equipment Demo

2. Testing

- › Test Fitting
- › Pilot Build and Review
- › Package Optimization based on Technician Feedback

3. Delivery

- › Delivery, Production, Installation Planning and Scheduling
- › Vehicle Status Tracking

4. Service

- › Dedicated Fleet Account Management Team
- › Distributor Service Support Network
- › Live Customer Service



A Clarience Technologies Company

**MAXIMIZE YOUR VAN'S
STORAGE SPACE AND
ORGANIZATION WITH
RANGER DESIGN!**

For the ultimate upfit solution, you can count on Ranger Design to deliver. Engineered for unmatched toughness, our products are built with exceptional craftsmanship and a flawless fit.

The perfect fit for your toughest jobs!



CONTACT US

cs@rangerdesign.com

1-800-565-5321

rangerdesign.com



Sprinter2026