

FORD  
**TRANSIT**

2026



# UPFIT GUIDE



A Clariance Technologies Company

# HELPING MOBILE TECHNICIANS WORK MORE EFFECTIVELY BY PROVIDING ORGANIZED STORAGE SOLUTIONS

**AT RANGER DESIGN,  
WE BELIEVE MORE IS POSSIBLE.**

We believe work vehicles and the technicians that drive them can become more organized, more efficient, more productive and more profitable. At Ranger Design we're committed to bringing you the products and services that make that possible.

More means helping you choose the right work van for your application, as well as giving you engineering support and expert advice to help design the most efficient work space in your new vehicle.

More also means getting that new van outfitted and on the road faster, so you can start using it for the reason you bought it.

We're committed to bringing you more, because we believe more is possible.

# HOW TO BUY

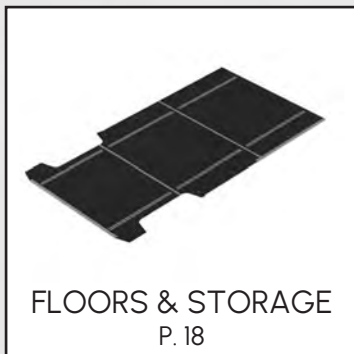
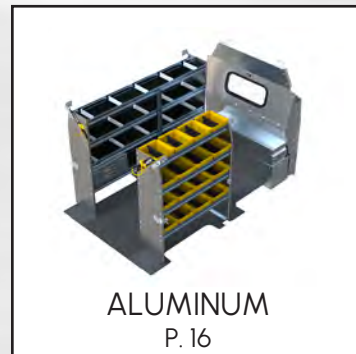
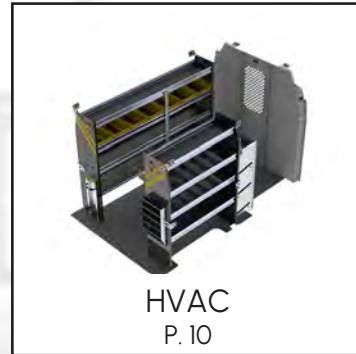
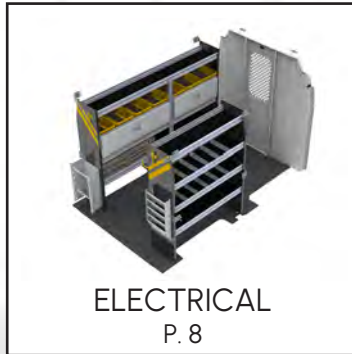

## Large Distributor Network Across the Continent

---

**Buy** Ranger Design Quickship service is available through your local distributor. [rangerdesign.com/find-distributor](http://rangerdesign.com/find-distributor)

---

**Lead Time** Quickship orders placed before 1PM EST, will ship from our factory within 48 hours.

---

## LAYOUT GUIDES

# HOW TO USE THE LAYOUT GUIDE

## INSIDE ROOF HEIGHT

To determine the maximum shelf height that can be used in the van.

## PARTITION DEPTH

This indicates the space taken up by our partition for this vehicle. Please note that this measurement is determined by the partition that encroaches the most. Some partitions may take up less space. Take note that this measurement may not necessarily be on the floor.

## DOOR OPENING

To determine where shelving will land in relation to the door opening. Use this measurement to determine the space available for drawer units.

## DIMENSIONS IN RED

These dimensions indicate unique measurements for each wheelbase. Use red dimensions to determine the exact wheelbase of your van.

## FLOOR SPACE

This area is usable floor space but due to curvature of the van there may not be the same available area at the roof. Please measure actual van for specific measurement at roof.

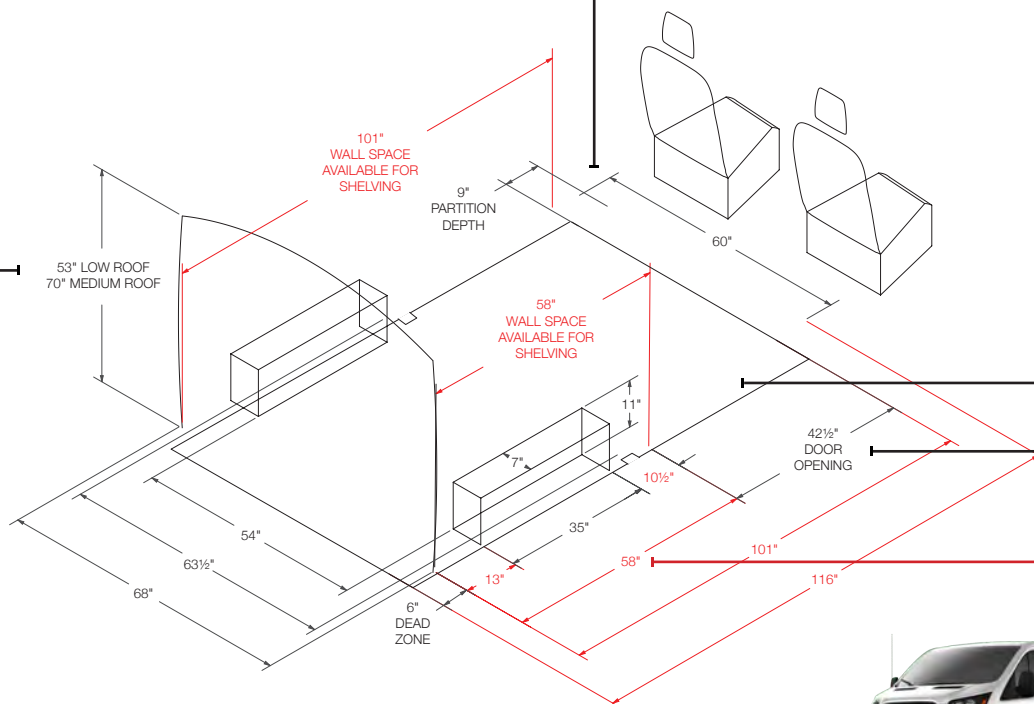

FORD  
TRANSIT  
Regular 130" Wheelbase



**FORD TRANSIT**  
Long 148" Wheelbase

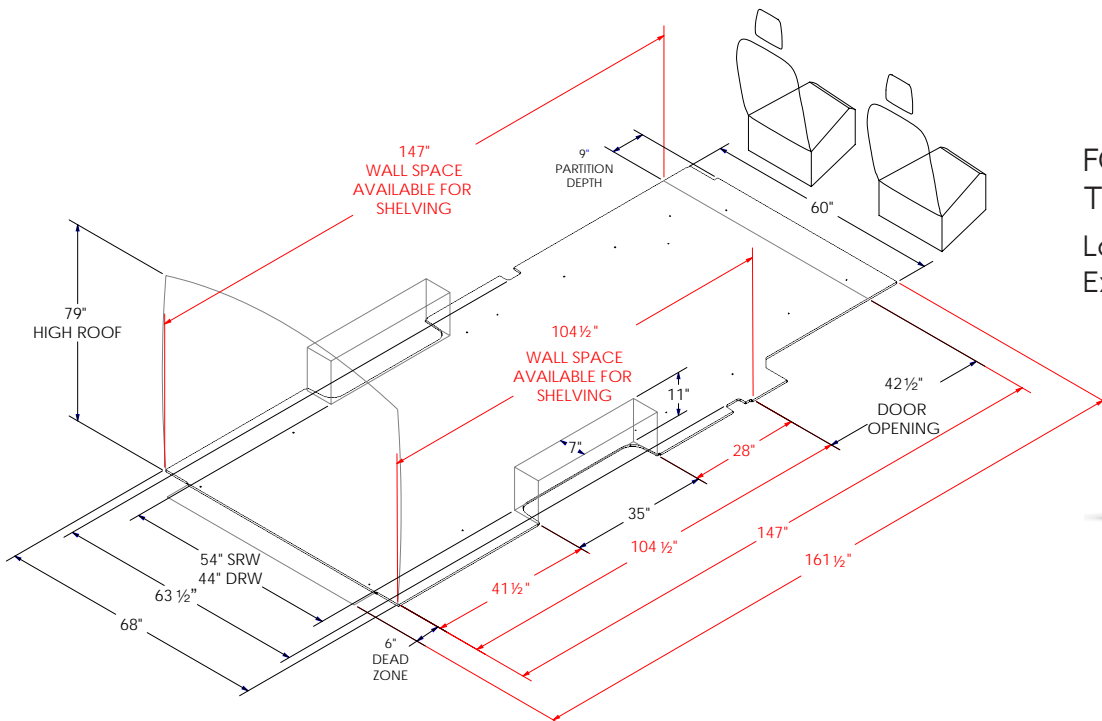
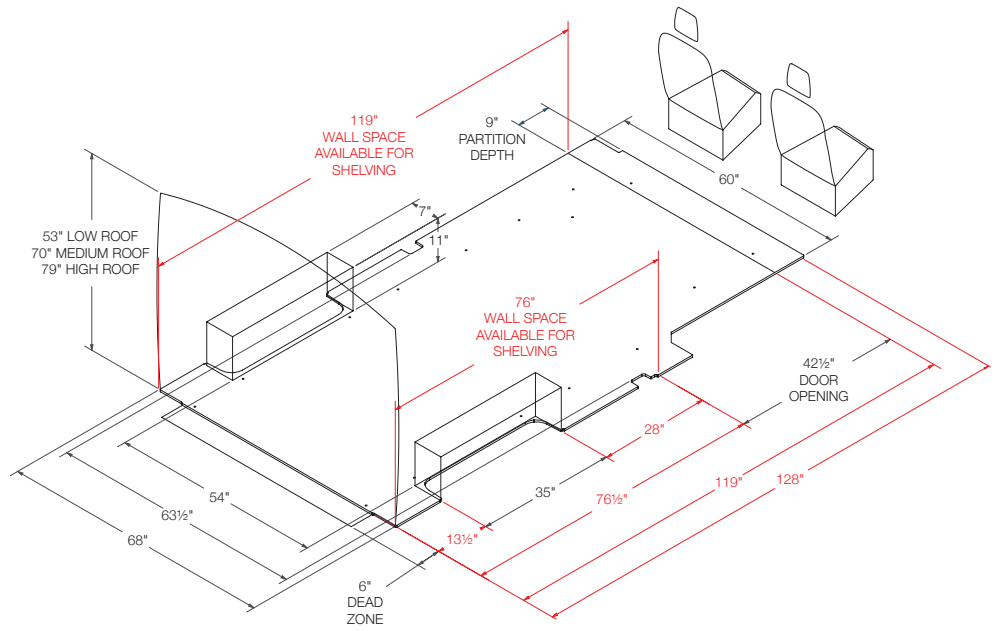

**FORD TRANSIT**  
Long 148" Wheelbase  
Extended



# CONTRACTOR PACKAGE

CONTRACTOR

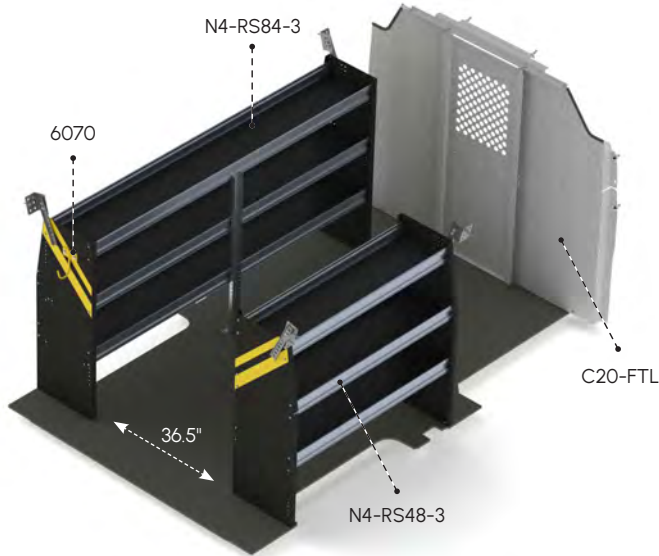

## FTL-10 CONTRACTOR

<b>MATERIAL</b>	Steel	<b>WHEELBASE</b>	130", 148"
<b>WEIGHT</b>	206 lbs	<b>ROOF HEIGHT</b>	Low
<b>INSTALL TIME</b>	3.3 hrs	<b>QUICKSHIP</b>	Yes

QTY	PART	DESCRIPTION
1	6070	6" Hook, 3" opening, painted
1	C20-FTL	Straight steel partition, perforated window, no access
1	N4-RS48-3	Steel shelving unit, 14" D x 48" W x 44.5" H
1	N4-RS84-3	Steel shelving unit, 14" D x 84" W x 44.5" H

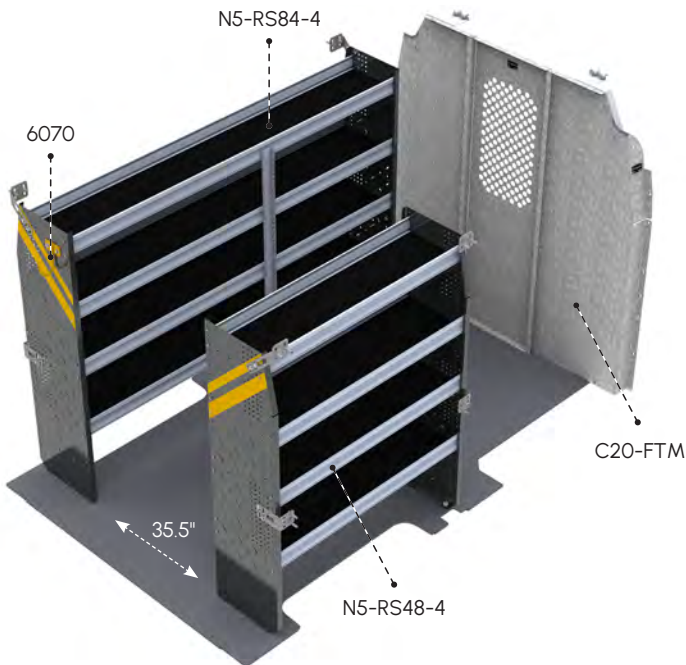

## FTR-10 CONTRACTOR

<b>MATERIAL</b>	Steel	<b>WHEELBASE</b>	130"
<b>WEIGHT</b>	268 lbs	<b>ROOF HEIGHT</b>	Medium
<b>INSTALL TIME</b>	3.8 hrs	<b>QUICKSHIP</b>	Yes

QTY	PART	DESCRIPTION
1	6070	6" Hook, 3" opening, painted
1	C20-FTM	Straight steel partition, perforated window, no access
1	N5-RS48-4	Steel shelving unit, 14" D x 48" W x 62" H
1	N5-RS84-4	Steel shelving unit, 14" D x 84" W x 62" H

VISIT  
RANGERDESIGN.COM  
TO VIEW OUR  
SAFETY PARTITIONS:



# CONTRACTOR PACKAGE

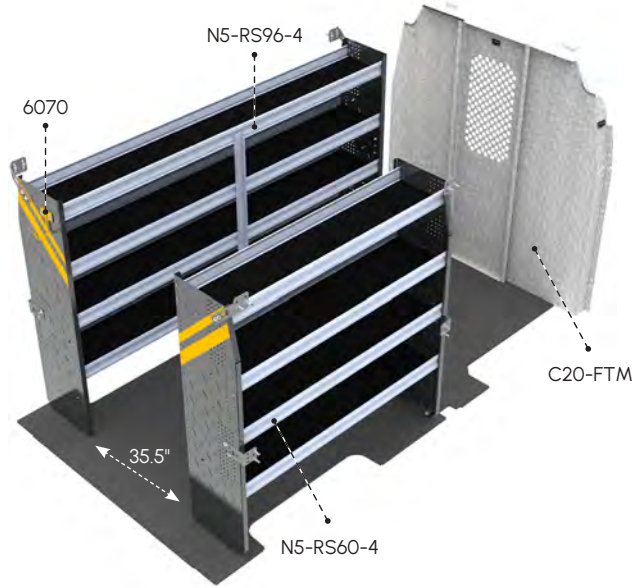

## FTM-10 CONTRACTOR

<b>MATERIAL</b>	Steel	<b>WHEELBASE</b>	148"
<b>WEIGHT</b>	288 lbs	<b>ROOF HEIGHT</b>	Medium
<b>INSTALL TIME</b>	3.8 hrs	<b>QUICKSHIP</b>	Yes

QTY	PART	DESCRIPTION
1	6070	6" Hook, 3" opening, painted
1	C20-FTM	Straight steel partition with perforated window, no access
1	N5-RS60-4	Steel shelving unit, 14" D x 60" W x 62" H
1	N5-RS96-4	Steel shelving unit, 14" D x 96" W x 62" H

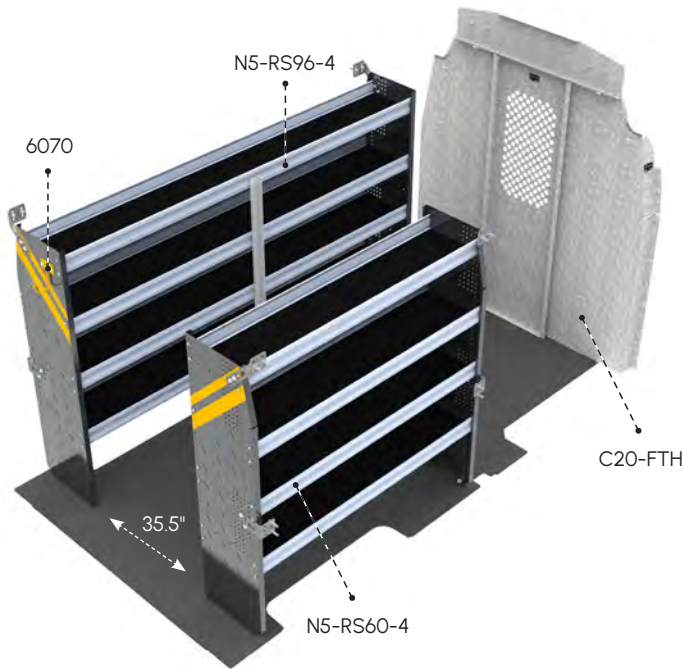

## FTH-10 CONTRACTOR

<b>MATERIAL</b>	Steel	<b>WHEELBASE</b>	148", 148" Ext.
<b>WEIGHT</b>	303 lbs	<b>ROOF HEIGHT</b>	High
<b>INSTALL TIME</b>	3.8 hrs	<b>QUICKSHIP</b>	Yes

QTY	PART	DESCRIPTION
1	6070	6" Hook, 3" opening, painted
1	C20-FTH	Straight steel partition with perforated window, no access
1	N5-RS60-4	Steel shelving unit, 14" D x 60" W x 62" H
1	N5-RS96-4	Steel shelving unit, 14" D x 96" W x 62" H

# ELECTRICAL PACKAGE

ELECTRICAL

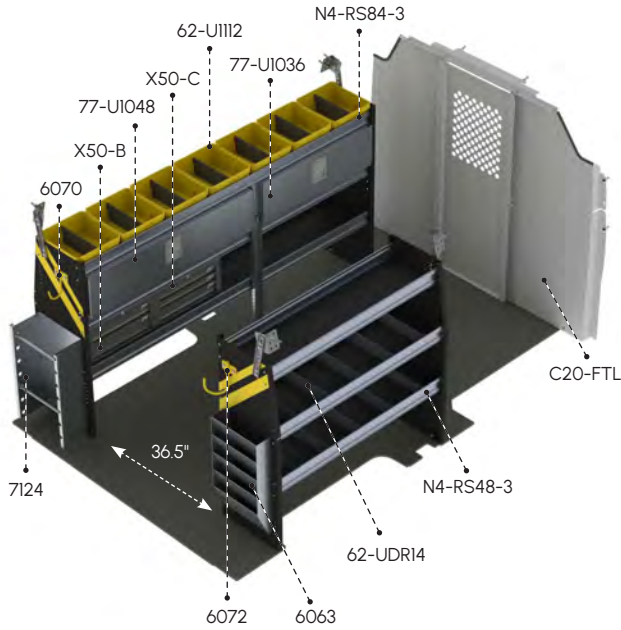

## FTL-11 ELECTRICAL

<b>MATERIAL</b>	Steel	<b>WHEELBASE</b>	130", 148"
<b>WEIGHT</b>	314 lbs	<b>ROOF HEIGHT</b>	Low
<b>INSTALL TIME</b>	5.8 hrs	<b>QUICKSHIP</b>	Yes

QTY	PART	DESCRIPTION
1	6063	Paper holder, extra deep, 5 slots
1	6070	6" Hook, 3" opening, painted
1	6072	8" Swivel hook, 4" opening, painted
7	62-U1112	12" Deep plastic bin
2	62-UDR14	Set of 5 dividers for a 14" shelf
1	7124	Reel holder with two 5/8" diameter rods
1	77-UI036	Adjustable shelving door unit - 33" W - for 36" and 72" shelves
1	77-UI048	Adjustable shelving door unit - 45" W - for 48" and 96" shelves
1	C20-FTL	Straight steel partition with perforated window, no access
1	N4-RS48-3	Steel shelving unit, 14" D x 48" W x 44.5" H
1	N4-RS84-3	Steel shelving unit, 14" D x 84" W x 44.5" H
1	X50-B	Compact 2-drawer unit
1	X50-C	Compact 3-drawer unit

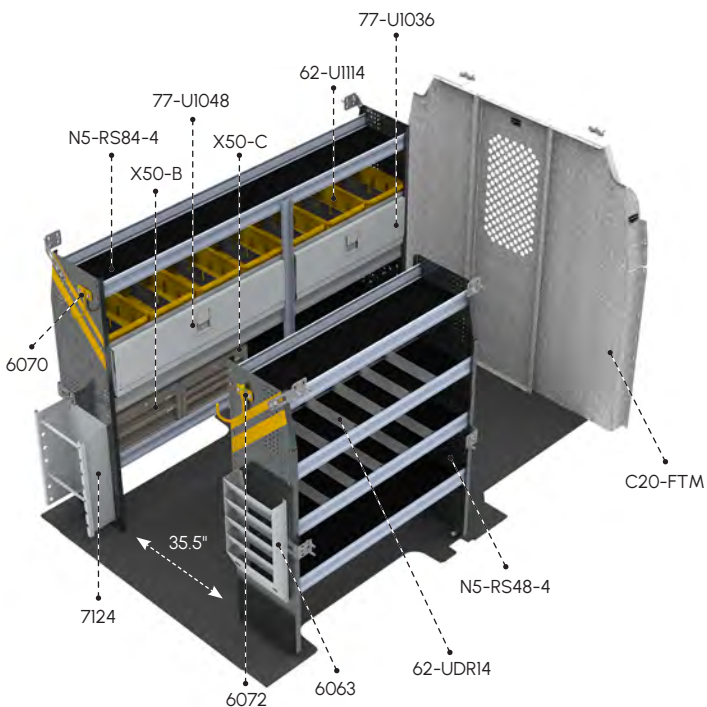

## FTR-11 ELECTRICAL

<b>MATERIAL</b>	Steel	<b>WHEELBASE</b>	130"
<b>WEIGHT</b>	377 lbs	<b>ROOF HEIGHT</b>	Medium
<b>INSTALL TIME</b>	6.3 hrs	<b>QUICKSHIP</b>	Yes

QTY	PART	DESCRIPTION
1	6063	Paper holder, extra deep, 5 slots
1	6070	6" Hook, 3" opening, painted
1	6072	8" Swivel hook, 4" opening, painted
7	62-U1114	14" Deep plastic bin
2	62-UDR14	Set of 5 dividers for a 14" shelf
1	7124	Reel holder with two 5/8" diameter rods
1	77-UI036	Adjustable shelving door unit - 33" W - for 36" and 72" shelves
1	77-UI048	Adjustable shelving door unit - 45" W - for 48" and 96" shelves
1	C20-FTM	Straight steel partition with perforated window, no access
1	N5-RS48-4	Steel shelving unit, 14" D x 48" W x 62" H
1	N5-RS84-4	Steel shelving unit, 14" D x 84" W x 62" H
1	X50-B	Compact 2-drawer unit
1	X50-C	Compact 3-drawer unit

# ELECTRICAL PACKAGE

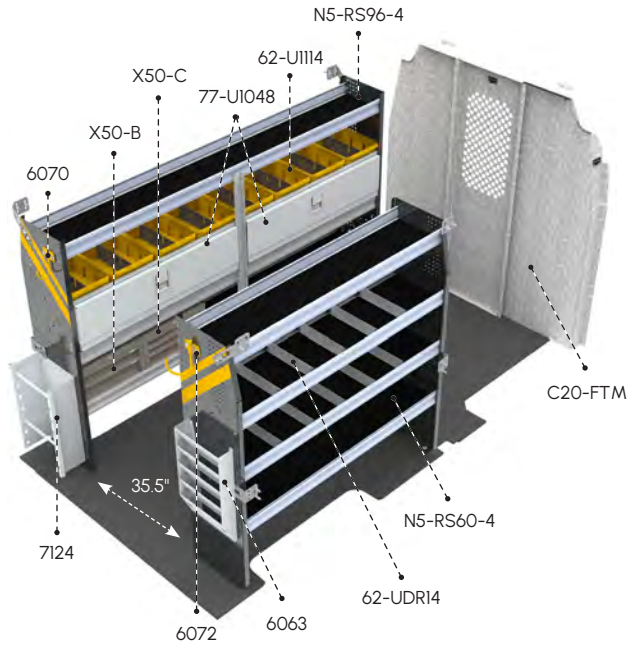

## FTM-11 ELECTRICAL

<b>MATERIAL</b>	Steel	<b>WHEELBASE</b>	148"
<b>WEIGHT</b>	401 lbs	<b>ROOF HEIGHT</b>	Medium
<b>INSTALL TIME</b>	6.3 hrs	<b>QUICKSHIP</b>	Yes

QTY	PART	DESCRIPTION
1	6063	Paper holder, extra deep, 5 slots
1	6070	6" Hook, 3" opening, painted
1	6072	8" Swivel hook, 4" opening, painted
8	62-U1114	14" Deep plastic bin
2	62-UDR14	Set of 5 dividers for a 14" shelf
1	7124	Reel holder with two 5/8" diameter rods
2	77-U1048	Adjustable shelving door unit - 45" W - for 48" and 96" shelves
1	C20-FTM	Straight steel partition with perforated window, no access
1	N5-RS60-4	Steel shelving unit, 14"D x 60" W x 62"H
1	N5-RS96-4	Steel shelving unit, 14"D x 96" W x 62"H
1	X50-B	Compact 2-drawer unit
1	X50-C	Compact 3-drawer unit

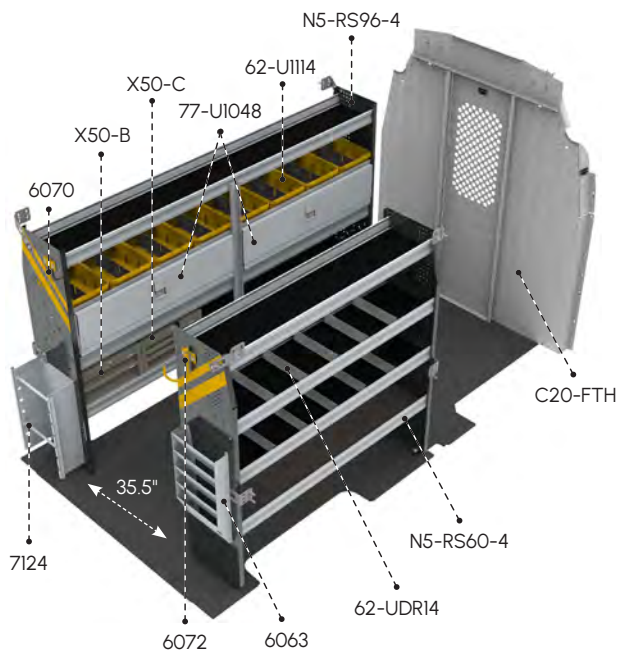

## FTH-11 ELECTRICAL

<b>MATERIAL</b>	Steel	<b>WHEELBASE</b>	148", 148" Ext.
<b>WEIGHT</b>	416 lbs	<b>ROOF HEIGHT</b>	High
<b>INSTALL TIME</b>	6.3 hrs	<b>QUICKSHIP</b>	Yes

QTY	PART	DESCRIPTION
1	6063	Paper holder, extra deep, 5 slots
1	6070	6" Hook, 3" opening, painted
1	6072	8" Swivel hook, 4" opening, painted
8	62-U1114	14" Deep plastic bin
2	62-UDR14	Set of 5 dividers for a 14" shelf
1	7124	Reel holder with two 5/8" diameter rods
2	77-U1048	Adjustable shelving door unit - 45" W - for 48" and 96" shelves
1	C20-FTH	Straight steel partition with perforated window, no access
1	N5-RS60-4	Steel shelving unit, 14"D x 60" W x 62"H
1	N5-RS96-4	Steel shelving unit, 14"D x 96" W x 62"H
1	X50-B	Compact 2-drawer unit
1	X50-C	Compact 3-drawer unit

# HVAC PACKAGE

HVAC

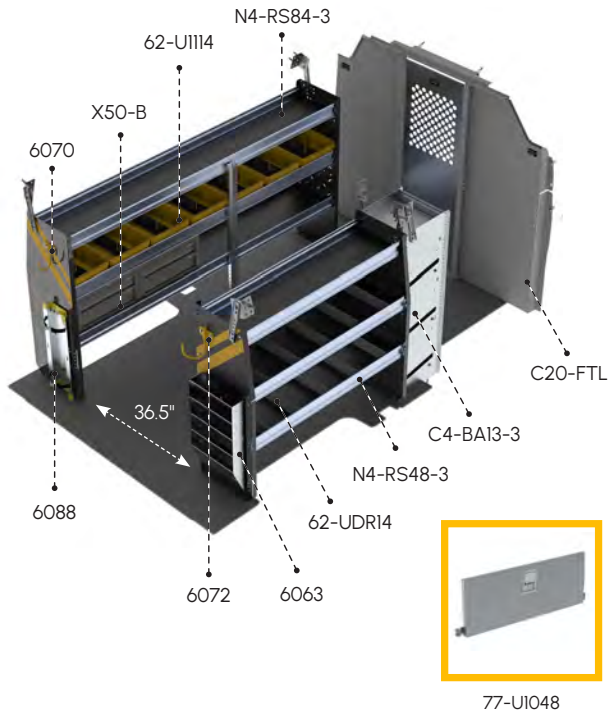

## FTL-12 HVAC

<b>MATERIAL</b>	Steel	<b>WHEELBASE</b>	130", 148"
<b>WEIGHT</b>	303 lbs	<b>ROOF HEIGHT</b>	Low
<b>INSTALL TIME</b>	5.6 hrs	<b>QUICKSHIP</b>	Yes

QTY	PART	DESCRIPTION
1	C4-BA13-3	3-Tier refrigerant rack for large bottles
1	6063	Paper holder, extra deep, 5 slots
1	6070	6" Hook, 3" opening, painted
1	6072	8" Swivel hook, 4" opening, painted
1	6088	Large aluminum bottle holder, with two black nylon straps
7	62-U1114	14" Deep plastic bin
2	62-UDR14	Set of 5 dividers for a 14" shelf
1	77-U1048	Adjustable shelving door unit - 45" W - for 48" & 96" shelves
1	C20-FTL	Straight steel partition with perforated window, no access
1	N4-RS48-3	Steel shelving unit, 14"D x 48" W x 44.5"H
1	N4-RS84-3	Steel shelving unit, 14"D x 84" W x 44.5"H
2	X50-B	Compact 2-drawer unit

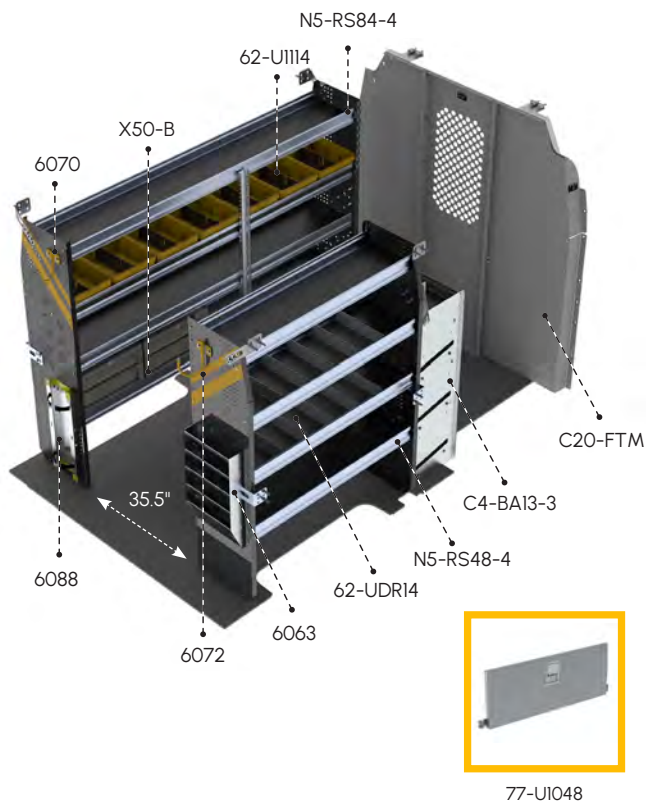

## FTR-12 HVAC

<b>MATERIAL</b>	Steel	<b>WHEELBASE</b>	130"
<b>WEIGHT</b>	366 lbs	<b>ROOF HEIGHT</b>	Medium
<b>INSTALL TIME</b>	6.1 hrs	<b>QUICKSHIP</b>	Yes

QTY	PART	DESCRIPTION
1	C4-BA13-3	3-Tier refrigerant rack for large bottles
1	6063	Paper holder, extra deep, 5 slots
1	6070	6" Hook, 3" opening, painted
1	6072	8" Swivel hook, 4" opening, painted
1	6088	Large aluminum bottle holder, with two black nylon straps
7	62-U1114	14" Deep plastic bin
2	62-UDR14	Set of 5 dividers for a 14" shelf
1	77-U1048	Adjustable shelving door unit - 45" W - for 48" & 96" shelves
1	C20-FTM	Straight steel partition with perforated window, no access
1	N5-RS48-4	Steel shelving unit, 14"D x 48" W x 62" H
1	N5-RS84-4	Steel shelving unit, 14"D x 84" W x 62" H
2	X50-B	Compact 2-drawer unit

# HVAC PACKAGE

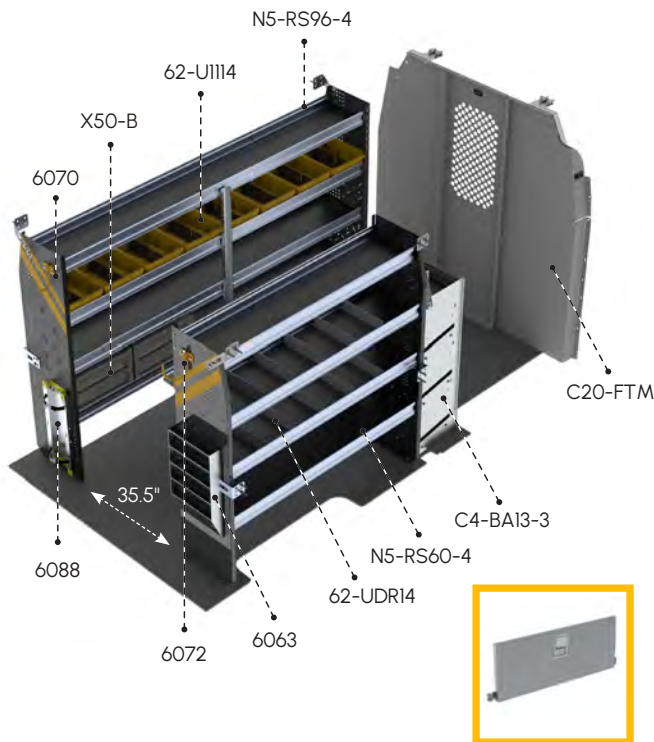

77-U1060

## FTM-12 HVAC

<b>MATERIAL</b>	Steel	<b>WHEELBASE</b>	148"
<b>WEIGHT</b>	389 lbs	<b>ROOF HEIGHT</b>	Medium
<b>INSTALL TIME</b>	6.1 hrs	<b>QUICKSHIP</b>	Yes

QTY	PART	DESCRIPTION
1	C4-BA13-3	3-Tier refrigerant rack for large bottles
1	6063	Paper holder, extra deep, 5 slots
1	6070	6" Hook, 3" opening, painted
1	6072	8" Swivel hook, 4" opening, painted
1	6088	Large aluminum bottle holder, with two black nylon straps
8	62-U1114	14" Deep plastic bin
2	62-UDR14	Set of 5 dividers for a 14" shelf
1	77-U1060	Adjustable shelving door unit - 57" W - for 60" shelves
1	C20-FTM	Straight steel partition with perforated window, no access
1	N5-RS60-4	Steel shelving unit, 14"D x 60" W x 62" H
1	N5-RS96-4	Steel shelving unit, 14"D x 96" W x 62" H
2	X50-B	Compact 2-drawer unit

HVAC

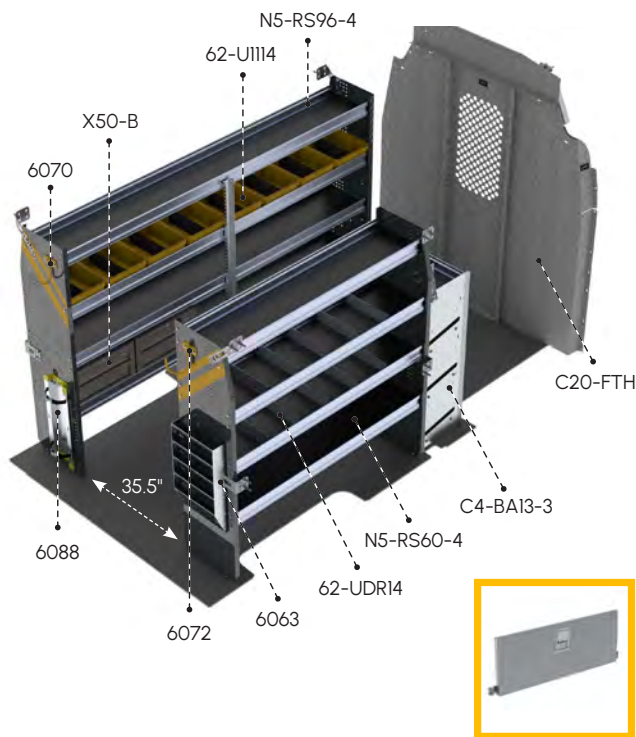

77-U1060

## FTH-12 HVAC

<b>MATERIAL</b>	Steel	<b>WHEELBASE</b>	148", 148" Ext.
<b>WEIGHT</b>	396 lbs	<b>ROOF HEIGHT</b>	High
<b>INSTALL TIME</b>	6.1 hrs	<b>QUICKSHIP</b>	Yes

QTY	PART	DESCRIPTION
1	C4-BA13-3	3-Tier refrigerant rack for large bottles
1	6063	Paper holder, extra deep, 5 slots
1	6070	6" Hook, 3" opening, painted
1	6072	8" Swivel hook, 4" opening, painted
1	6088	Large aluminum bottle holder, with two black nylon straps
8	62-U1114	14" Deep plastic bin
2	62-UDR14	Set of 5 dividers for a 14" shelf
1	77-U1060	Adjustable shelving door unit - 57" W - for 60" shelves
1	C20-FTH	Straight steel partition with perforated window, no access
1	N5-RS60-4	Steel shelving unit, 14"D x 60" W x 62" H
1	N5-RS96-4	Steel shelving unit, 14"D x 96" W x 62" H
2	X50-B	Compact 2-drawer unit

# SERVICE PACKAGE

SERVICE

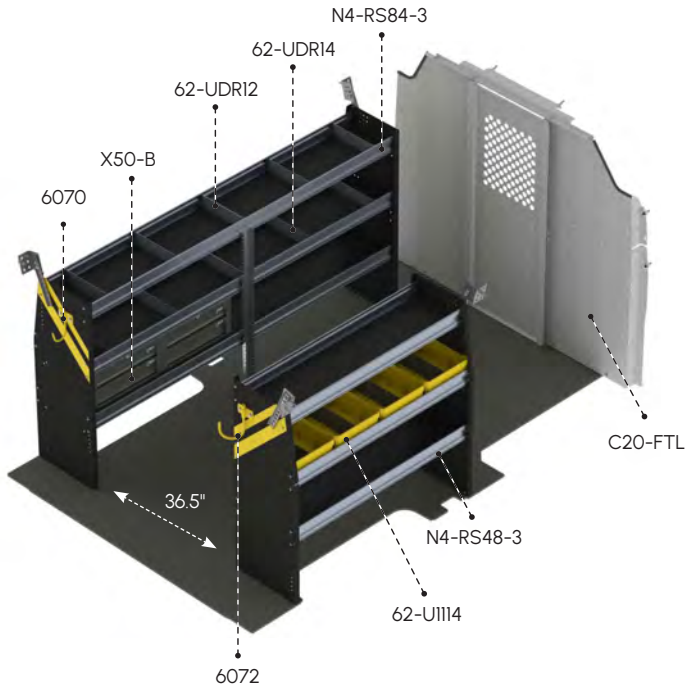

## FTL-16 SERVICE

<b>MATERIAL</b>	Steel	<b>WHEELBASE</b>	130", 148"
<b>WEIGHT</b>	273 lbs	<b>ROOF HEIGHT</b>	Low
<b>INSTALL TIME</b>	4.1 hrs	<b>QUICKSHIP</b>	Yes

QTY	PART	DESCRIPTION
1	6070	6" Hook, 3" opening, painted
1	6072	8" Swivel hook, 4" opening, painted
4	62-U1114	14" Deep plastic bin
1	62-UDR12	Set of 5 dividers for a 12" shelf
1	62-UDR14	Set of 5 dividers for a 14" shelf
1	C20-FTL	Straight steel partition with perforated window, no access
1	N4-RS48-3	Steel shelving unit, 14"D x 48" W x 44.5"H
1	N4-RS84-3	Steel shelving unit, 14"D x 84" W x 44.5"H
2	X50-B	Compact 2-drawer unit

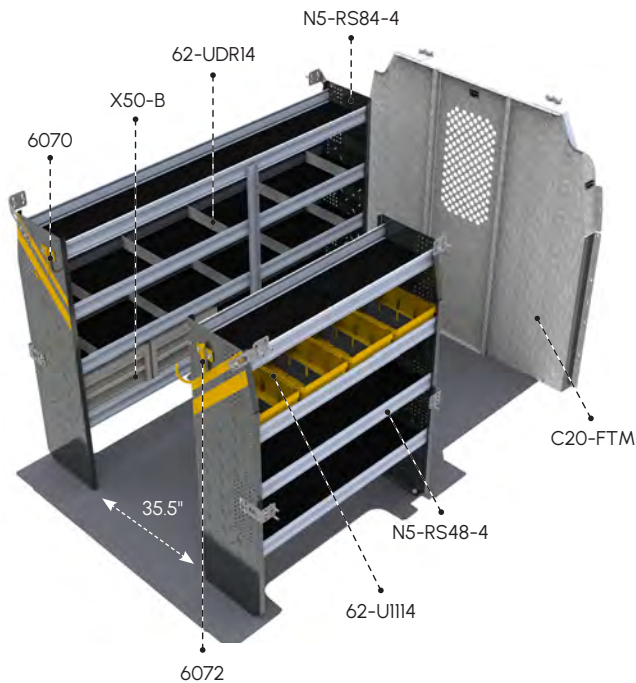

## FTR-16 SERVICE

<b>MATERIAL</b>	Steel	<b>WHEELBASE</b>	130"
<b>WEIGHT</b>	336 lbs	<b>ROOF HEIGHT</b>	Medium
<b>INSTALL TIME</b>	4.6 hrs	<b>QUICKSHIP</b>	Yes

QTY	PART	DESCRIPTION
1	6070	6" Hook, 3" opening, painted
1	6072	8" Swivel hook, 4" opening, painted
4	62-U1114	14" Deep plastic bin
2	62-UDR14	Set of 5 dividers for a 14" shelf
1	C20-FTM	Straight steel partition with perforated window, no access
1	N5-RS48-4	Steel shelving unit, 14"D x 48" W x 62"H
1	N5-RS84-4	Steel shelving unit, 14"D x 84" W x 62"H
2	X50-B	Compact 2-drawer unit

# SERVICE PACKAGE

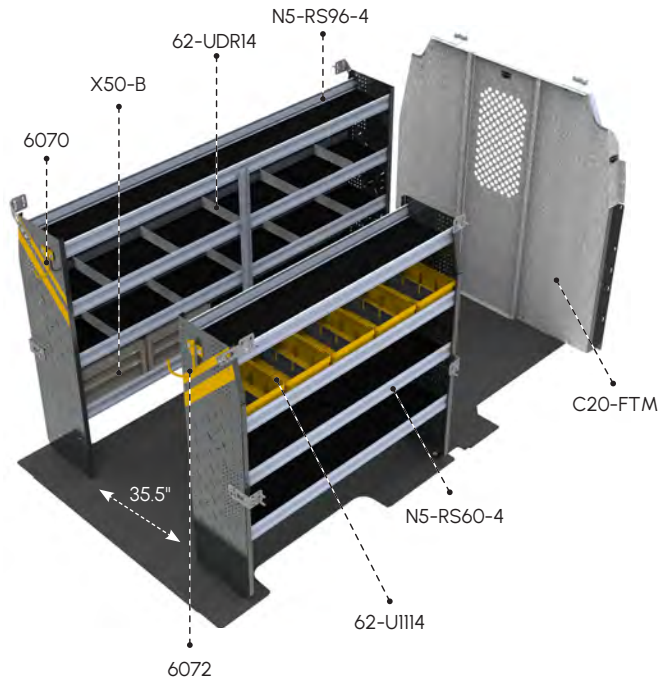

## FTM-16 SERVICE

<b>MATERIAL</b>	Steel	<b>WHEELBASE</b>	148"
<b>WEIGHT</b>	358 lbs	<b>ROOF HEIGHT</b>	Medium
<b>INSTALL TIME</b>	4.6 hrs	<b>QUICKSHIP</b>	Yes

QTY	PART	DESCRIPTION
1	6070	6" Hook, 3" opening, painted
1	6072	8" Swivel hook, 4" opening, painted
5	62-U1114	14" Deep plastic bin
2	62-UDR14	Set of 5 dividers for a 14" shelf
1	C20-FTM	Straight steel partition with perforated window, no access
1	N5-RS60-4	Steel shelving unit, 14" D x 60" W x 62" H
1	N5-RS96-4	Steel shelving unit, 14" D x 96" W x 62" H
2	X50-B	Compact 2-drawer unit

SERVICE

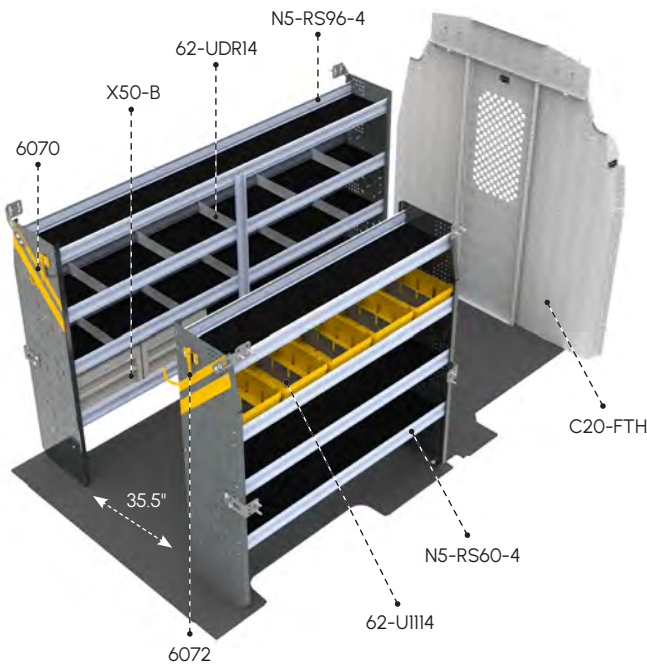

## FTH-16 SERVICE

<b>MATERIAL</b>	Steel	<b>WHEELBASE</b>	148", 148" Ext.
<b>WEIGHT</b>	373 lbs	<b>ROOF HEIGHT</b>	High
<b>INSTALL TIME</b>	4.6 hrs	<b>QUICKSHIP</b>	Yes

QTY	PART	DESCRIPTION
1	6070	6" Hook, 3" opening, painted
1	6072	8" Swivel hook, 4" opening, painted
5	62-U1114	14" Deep plastic bin
2	62-UDR14	Set of 5 dividers for a 14" shelf
1	C20-FTH	Straight steel partition with perforated window, no access
1	N5-RS60-4	Steel shelving unit, 14" D x 60" W x 62" H
1	N5-RS96-4	Steel shelving unit, 14" D x 96" W x 62" H
2	X50-B	Compact 2-drawer unit

# DELIVERY PACKAGE

DELIVERY

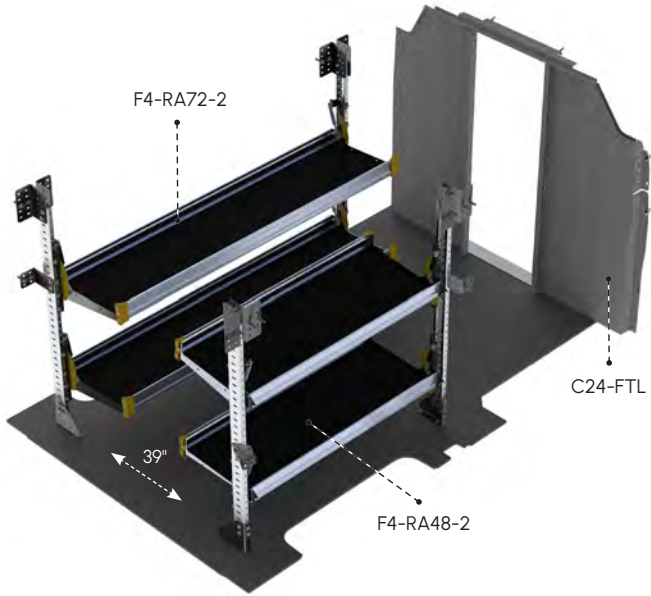

## FTL-19 DELIVERY

<b>MATERIAL</b>	Aluminum	<b>WHEELBASE</b>	130", 148"
<b>WEIGHT</b>	196 lbs	<b>ROOF HEIGHT</b>	Low
<b>INSTALL TIME</b>	4.4 hrs	<b>QUICKSHIP</b>	Yes

QTY	PART	DESCRIPTION
1	<b>C24-FTL</b>	Straight walk-through steel partition
1	<b>F4-RA72-2</b>	Fold-away unit, 2 levels, 22" D x 72" W x 47" H
1	<b>F4-RA48-2</b>	Fold-away unit, 2 levels, 22" D x 48" W x 47" H

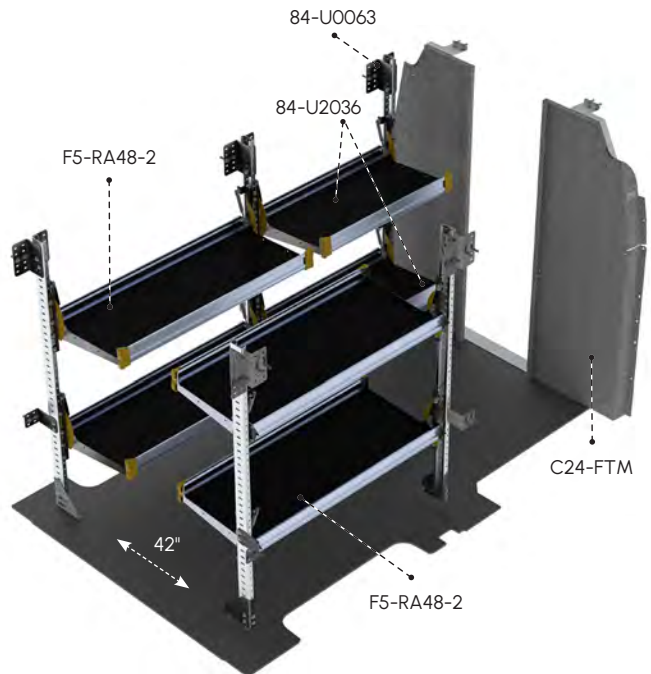

## FTR-19 DELIVERY

<b>MATERIAL</b>	Aluminum	<b>WHEELBASE</b>	130"
<b>WEIGHT</b>	257 lbs	<b>ROOF HEIGHT</b>	Medium
<b>INSTALL TIME</b>	5.5 hrs	<b>QUICKSHIP</b>	Yes

QTY	PART	DESCRIPTION
1	<b>84-U0063</b>	Post assembly for fold-away shelving, 63"
2	<b>84-U2036</b>	Fold-away shelf tray, 20" D x 36" W
1	<b>C24-FTM</b>	Straight walk-through steel partition
2	<b>F5-RA48-2</b>	Fold-away unit, 2 levels, 25" D x 48" W x 63" H

# DELIVERY PACKAGE

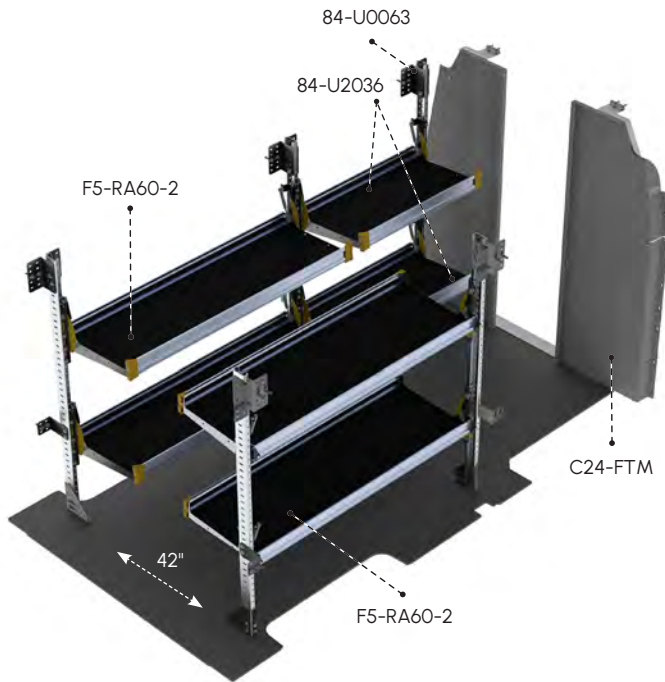

## FTM-19 DELIVERY

<b>MATERIAL</b>	Aluminum	<b>WHEELBASE</b>	148"
<b>WEIGHT</b>	270 lbs	<b>ROOF HEIGHT</b>	Medium
<b>INSTALL TIME</b>	5.5 hrs	<b>QUICKSHIP</b>	Yes

QTY	PART	DESCRIPTION
1	84-U0063	Post assembly for fold-away shelving, 63"
2	84-U2036	Fold-away shelf tray, 20" D x 36" W
1	C24-FTM	Straight walk-through steel partition
2	F5-RA60-2	Fold-away unit, 2 levels, 25" D x 60" W x 63" H

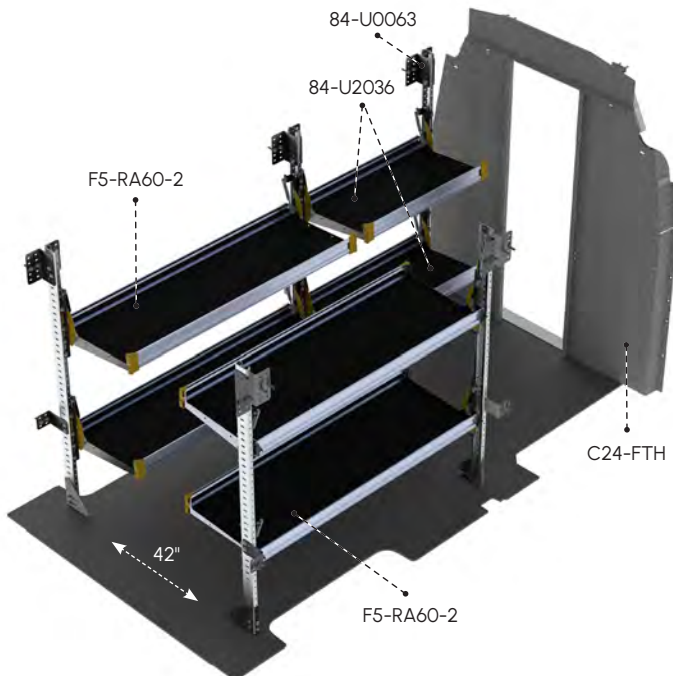

## FTH-19 DELIVERY

<b>MATERIAL</b>	Aluminum	<b>WHEELBASE</b>	148", 148" Ext.
<b>WEIGHT</b>	277 lbs	<b>ROOF HEIGHT</b>	High
<b>INSTALL TIME</b>	5.5 hrs	<b>QUICKSHIP</b>	Yes

QTY	PART	DESCRIPTION
1	84-U0063	Post assembly for fold-away shelving, 63"
2	84-U2036	Fold-away shelf tray, 20" D x 36" W
1	C24-FTH	Straight walk-through steel partition
2	F5-RA60-2	Fold-away unit, 2 levels, 25" D x 60" W x 63" H

# ALUMINUM PACKAGE

## FTL-27 ALUMINUM

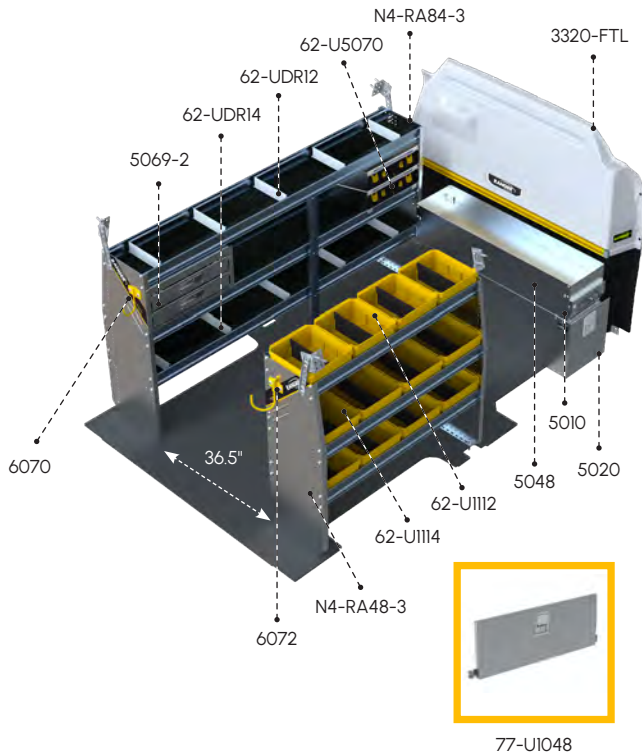

<b>MATERIAL</b>	Aluminum	<b>WHEELBASE</b>	130", 148"
<b>WEIGHT</b>	343 lbs	<b>ROOF HEIGHT</b>	Low
<b>INSTALL TIME</b>	7.3 hrs	<b>QUICKSHIP</b>	Yes

QTY	PART	DESCRIPTION
1	3320-FTL	Max View Contoured safety partition
1	5010	Partslider 48" D
1	5020	Tool drawer 48" D × 14" W × 16" H
1	5048	Top edge
1	5069-2	2-Drawer cabinet
2	62-U5070	Partskeeper carry case with holder
1	6070	6" Hook, 3" opening, painted
1	6072	8" Swivel hook, 4" opening, painted
4	62-U1112	12" Deep plastic bin
8	62-U1114	14" Deep plastic bin
1	62-UDR12	Set of 5 dividers for a 12" shelf
1	62-UDR14	Set of 5 dividers for a 14" shelf
1	77-UI048	Adjustable shelving door unit - 45" W - for 48" & 96" shelves
1	N4-RA48-3	Aluminum shelving unit, 14"D × 48" W × 44.5" H
1	N4-RA84-3	Aluminum shelving unit, 14"D × 84" W × 44.5" H

## FTR-27 ALUMINUM

ALUMINUM

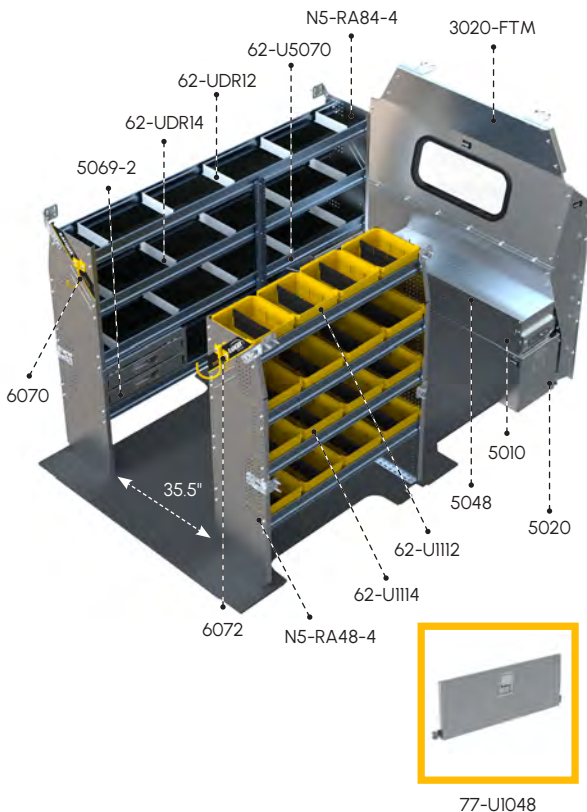

<b>MATERIAL</b>	Aluminum	<b>WHEELBASE</b>	130"
<b>WEIGHT</b>	426 lbs	<b>ROOF HEIGHT</b>	Medium
<b>INSTALL TIME</b>	7.3 hrs	<b>QUICKSHIP</b>	Yes

QTY	PART	DESCRIPTION
1	3020-FTM	Contoured safety partition with glass window
1	5010	Partslider 48" D
1	5020	Tool drawer 48" D × 14" W × 16" H
1	5048	Top edge
1	5069-2	2-Drawer cabinet
2	62-U5070	Partskeeper carry case with holder
1	6070	6" Hook, 3" opening, painted
1	6072	8" Swivel hook, 4" opening, painted
4	62-U1112	12" Deep plastic bin
12	62-U1114	14" Deep plastic bin
1	62-UDR12	Set of 5 dividers for a 12" shelf
2	62-UDR14	Set of 5 dividers for a 14" shelf
1	77-UI048	Adjustable shelving door unit - 45" W - for 48" & 96" shelves
1	N5-RA48-4	Aluminum shelving unit, 14"D × 48" W × 62" H
1	N5-RA84-4	Aluminum shelving unit, 14"D × 84" W × 62" H

# ALUMINUM PACKAGE

## FTM-27 ALUMINUM

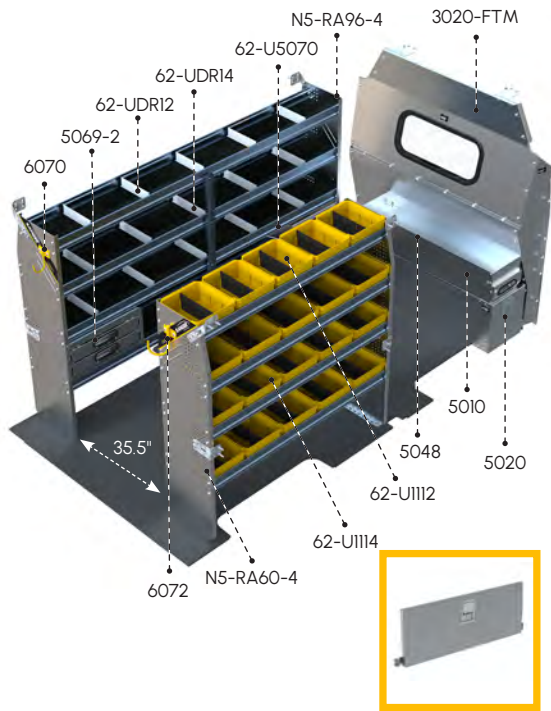

77-UI060

<b>MATERIAL</b>	Aluminum	<b>WHEELBASE</b>	148"
<b>WEIGHT</b>	449 lbs	<b>ROOF HEIGHT</b>	Medium
<b>INSTALL TIME</b>	7.3 hrs	<b>QUICKSHIP</b>	Yes

QTY	PART	DESCRIPTION
1	3020-FTM	Contoured safety partition with glass window
1	5010	Partslider 48" D
1	5020	Tool drawer 48" D x 14" W x 16" H
1	5048	Top edge
1	5069-2	2-Drawer cabinet
2	62-U5070	Partskeeper cabinets
1	6070	6" Hook, 3" opening, painted
1	6072	8" Swivel hook, 4" opening, painted
5	62-U1112	12" Deep plastic bin
15	62-U1114	14" Deep plastic bin
1	62-UDR12	Set of 5 dividers for a 12" shelf
2	62-UDR14	Set of 5 dividers for a 14" shelf
1	77-UI060	Adjustable shelving door unit - 57" W - for 60" shelves
1	N5-RA60-4	Aluminum shelving unit, 14" D x 60" W x 62" H
1	N5-RA96-4	Aluminum shelving unit, 14" D x 96" W x 62" H

## FTH-27 ALUMINUM

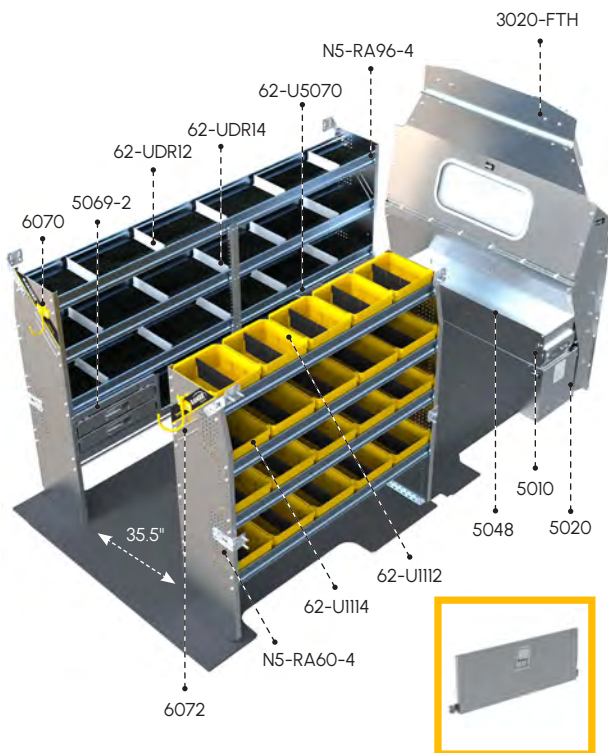

77-UI060

<b>MATERIAL</b>	Aluminum	<b>WHEELBASE</b>	148", 148" Ext.
<b>WEIGHT</b>	454 lbs	<b>ROOF HEIGHT</b>	High
<b>INSTALL TIME</b>	7.3 hrs	<b>QUICKSHIP</b>	Yes

QTY	PART	DESCRIPTION
1	3020-FTH	Contoured safety partition with glass window
1	5010	Partslider 48" D
1	5020	Tool drawer 48" D x 14" W x 16" H
1	5048	Top edge
1	5069-2	2-Drawer cabinet
2	62-U5070	Partskeeper cabinets
1	6070	6" Hook, 3" opening, painted
1	6072	8" Swivel hook, 4" opening, painted
5	62-U1112	12" Deep plastic bin
15	62-U1114	14" Deep plastic bin
1	62-UDR12	Set of 5 dividers for a 12" shelf
2	62-UDR14	Set of 5 dividers for a 14" shelf
1	77-UI060	Adjustable shelving door unit - 57" W - for 60" shelves
1	N5-RA60-4	Aluminum shelving unit, 14" D x 60" W x 62" H
1	N5-RA96-4	Aluminum shelving unit, 14" D x 96" W x 62" H

# E-FLOORS

Easy. Efficient. EV Ready. Compatible with both electric and gas powered vehicles.



## 6541-FTS

Ford Transit E-Floor

### MARINE-GRADE PLYWOOD

WHEELBASE	130"
WEIGHT	77 lbs



## 6541-FTL

Ford Transit E-Floor

### MARINE-GRADE PLYWOOD

WHEELBASE	148"
WEIGHT	90 lbs



## 6541-FTX

Ford Transit E-Floor

### MARINE-GRADE PLYWOOD

WHEELBASE	148" Ext.
WEIGHT	111 lbs

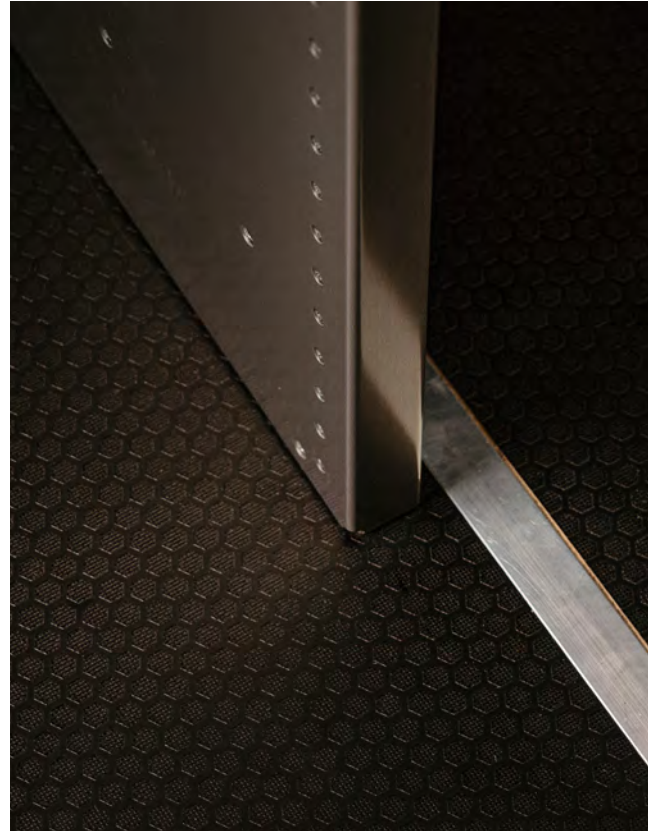

TRANSIT E-FLOOR

# DRAWERS

Increase storage and organization with Ranger Design's line of drawer units.

FLOORS



## 5010

Partslider drawer

### ALUMINUM

DIMENSIONS	48" D x 12" W x 6" H
WEIGHT CAPACITY	150 lbs
WEIGHT	25 lbs



## 5020

Tool drawer

### ALUMINUM

DIMENSIONS	48" D x 14" W x 16" H
WEIGHT CAPACITY	320 lbs
WEIGHT	70 lbs



## 5048

Top edge, for 5010 Partslider

### ALUMINUM

DIMENSIONS	48" D x 12" W x 4" H
WEIGHT CAPACITY	—
WEIGHT	8 lbs



**TOOL DRAWER TIP:** Stack these drawers for maximum efficiency

# STORAGE UNITS

Ergonomic storage solutions for the cargo space in your vehicle.



**CABINET FOR MILWAUKEE ORGANIZERS**



## 62-U5076

Shelf Mount for Milwaukee Organizers and Toolboxes

<b>ALUMINUM</b>	
<b>DIMENSIONS</b>	3.3" D × 22.8" W × 14.7" H
<b>WEIGHT</b>	3.6 lbs



## C5-MA20-6

2-Shelf Cabinet for Milwaukee Packout Organizers

<b>ALUMINUM</b>	
<b>DIMENSIONS</b>	14.9" D × 21.8" W × 62" H
<b>WEIGHT</b>	40 lbs



## C5-PA18-8

Partskeeper Cabinet with 8 Carry Cases and 2 shelves

<b>ALUMINUM</b>	
<b>DIMENSIONS</b>	14" D × 19" W × 62" H
<b>WEIGHT</b>	68 lbs



## N5-PS20-8

Partskeeper Cabinet with 8 Carry Cases and 2 shelves

<b>STEEL</b>	
<b>DIMENSIONS</b>	16" D × 20" W × 62" H
<b>WEIGHT</b>	89 lbs



## N5-LA16-1

Locker with top shelf and 2 hooks

<b>ALUMINUM</b>	
<b>DIMENSIONS</b>	16" D × 14" W × 62" H
<b>WEIGHT</b>	41 lbs



## N5-LS16-1

Locker with top shelf and 2 hooks

<b>STEEL</b>	
<b>DIMENSIONS</b>	16" D × 14" W × 62" H
<b>WEIGHT</b>	54 lbs

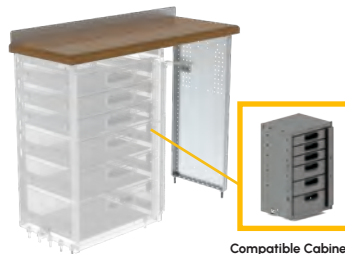

Compatible Cabinets  
5060-5, 5060-6, 5060-8  
(Sold separately)

## S3-WA48-0

Workbench with hardwood top, 1 end-panel

<b>ALUMINUM</b>	
<b>DIMENSIONS</b>	18" D × 48" W × 40" H
<b>WEIGHT</b>	49 lbs



## S3-WA48-1

Workbench with hardwood top, 1 shelf tray

<b>ALUMINUM</b>	
<b>DIMENSIONS</b>	18" D × 48" W × 40" H
<b>WEIGHT</b>	66 lbs

STORAGE UNITS

# ACCESSORIES

Choose the finishing details to tailor the upfit to your specific needs.

## CARGO HOLDERS

Keep your equipment organized with a dedicated storage spot. No more loose reels or cans on the floor. Everything stays secure and easy to reach.



**6057**

Can Holder

<b>ALUMINUM</b>	
<b>DIMENSIONS</b>	3" D × 8.5" W × 3" H
<b>WEIGHT</b>	1 lb



**6061**

2-Slot Paper Holder, extra deep

<b>ALUMINUM</b>	
<b>DIMENSIONS</b>	3.75" D × 12.75" W × 12" H
<b>WEIGHT</b>	2 lbs



**6063**

5-Slot Paper Holder, extra deep

<b>ALUMINUM</b>	
<b>DIMENSIONS</b>	3.75" D × 12.75" W × 24" H
<b>WEIGHT</b>	7 lbs



**6068**

Wire Hard Hat Holder

<b>STEEL</b>	
<b>DIMENSIONS</b>	—
<b>WEIGHT</b>	1 lb



**7124**

Reel Holder, two 5/8" rods

<b>ALUMINUM</b>	
<b>DIMENSIONS</b>	7.25" D × 15" W × 24" H
<b>WEIGHT</b>	11 lbs



**5-SLOT PAPER HOLDER ON STEEL SHELF UNIT**

## STORAGE HOOKS

Keep frequently used items such as hats, vests and extension cords hanging within easy reach in your vehicle.



**6070**

6" Hook, 3" opening

<b>STEEL</b>	
<b>DIMENSIONS</b>	3" D
<b>WEIGHT</b>	2 lbs



**6071**

Triple 6" Hook, 3" opening

<b>STEEL</b>	
<b>DIMENSIONS</b>	4" D
<b>WEIGHT</b>	1 lbs



**6073**

Large Movable Hook

<b>ALUMINUM</b>	
<b>DIMENSIONS</b>	6.5" D × 2.75" W × 4" H
<b>WEIGHT</b>	1 lb

## DRIVER SAFETY

Enhance road safety with accessories that improve visibility, ventilation, and overall awareness. From improved airflow to increased visibility, these features help create a safe driving environment.

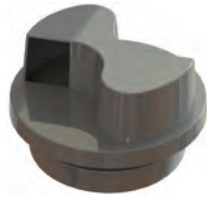

**6050**

Flettner Vent, rotary design (4" H above and 1.4" H below)

PLASTIC	
<b>DIAMETER</b>	8.88"
<b>WEIGHT</b>	2 lbs



**6082**

Triangle Kit and Holder with 3 triangles

ALUMINUM	
<b>DIMENSIONS</b>	5.2" D x 6.4" W x 21.5" H
<b>WEIGHT</b>	15 lb



**6090**

Back up Alarm, die cast housing, encapsulated circuitry

OTHER	
<b>DIMENSIONS</b>	—
<b>WEIGHT</b>	1 lbs

## LED LIGHTING

Keeps the cargo space bright and visible, no matter what time of day or night. Eliminate any chance of injury when searching through your tools in the dark.

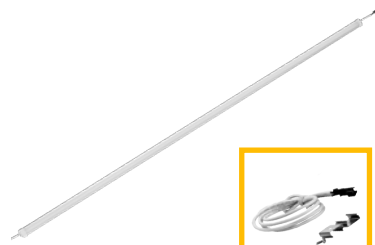

**6092-42**

Universal LED Light Kit for vans (12V DC / 1200 Lm / 10W)

OTHER	
<b>DIMENSIONS</b>	42" L x 1" H
<b>WEIGHT</b>	1 lb

## GRAB HANDLE

Install a Grab Handle for maximum support and stability when climbing into your van. Grab Handles can also act as tie downs for extra cargo during transport.



**6093-27**

Large Grab Handle

STEEL	
<b>DIMENSIONS</b>	18" W x 30" H x 3.5" D
<b>WEIGHT</b>	3 lbs



## REAR MAX STEP

Climbing in and out of your van several times a day can put a strain on your legs and back. The Max Step gives tradespeople quick and easy access to their cargo space without the effort.

**6550-FT**

Max Step for the Ford Transit

STEEL	
<b>DIMENSIONS</b>	32" D x 56" W x 2.5" H
<b>WEIGHT</b>	48 lbs



VISIT OUR WEBSITE TO VIEW MORE ACCESSORIES

# ROOF RACKS

Increase efficiency with the right roof rack for your job.



## CARGO+ RACK

ALUMINUM			
PART	WHEELBASE	ROOF HEIGHT	LADDER LENGTH
1506-FTL	148"	Low / Medium	-
1506-FTR	130"	Low / Medium	-
1506-FTX	148" Ext	High	-



## CARGO RACK

ALUMINUM			
PART	WHEELBASE	ROOF HEIGHT	LADDER LENGTH
1605-FTL	148", 148" Ext	Low / Medium / High	-
1605-FTR	130"	Low / Medium	-
1605-FTL3	148", 148" Ext	Low / Medium / High	-
1605-FTR3	130"	Low / Medium	-



## COMBINATION RACK

ALUMINUM			
PART	WHEELBASE	ROOF HEIGHT	LADDER LENGTH
1625-FTL	148", 148" Ext	Low / Medium / High	32 ft
1625-FTR	130"	Low / Medium	32 ft



## DOUBLE CLAMP RACK

ALUMINUM			
PART	WHEELBASE	ROOF HEIGHT	LADDER LENGTH
1630-FTL	148", 148" Ext	Low / Medium / High	32 ft
1630-FTR	130"	Low / Medium	32 ft
1630-FTL3	148", 148" Ext	Low / Medium / High	32 ft
1630-FTR3	130"	Low / Medium	32 ft



## MAX RACK

ALUMINUM			
PART	WHEELBASE	ROOF HEIGHT	LADDER LENGTH
1870-FTL	148", 148" Ext	Medium / High	32 ft
1870-FTR	130"	Medium	32 ft
1880-FTL	148", 148" Ext	Medium / High	32 ft
1880-FTR	130"	Medium	32 ft
1880-FTL3	148", 148" Ext	Medium / High	32 ft
1880-FTR3	130"	Medium	32 ft



## ACCESS STOW

ALUMINUM			
PART	WHEELBASE	ROOF HEIGHT	LADDER LENGTH
1920-FTL	148", 148" Ext	Low / Medium / High	32 ft
1920-FTR	130"	Low / Medium / High	32 ft
1930-FTL	148", 148" Ext	Low / Medium / High	32 ft
1930-FTR	130"	Low / Medium / High	32 ft



CHECK OUT OUR REAR ACCESS LADDER BY PRIME DESIGN



# TURNKEY FLEET SERVICES



## Ship Through or Local Installation Across North America for all Types of Cargo Vans

We are pleased to offer an efficient, personalized service to answer all questions regarding:

### 1. Analysis

- › Cargo Needs Analysis
- › Custom 3D CAD Layouts
- › Hands-on Equipment Demo

### 2. Testing

- › Test Fitting
- › Pilot Build and Review
- › Package Optimization based on Technician Feedback

### 3. Delivery

- › Delivery, Production, Installation Planning and Scheduling
- › Vehicle Status Tracking

### 4. Service

- › Dedicated Fleet Account Management Team
- › Distributor Service Support Network
- › Live Customer Service



A Clarience Technologies Company

**MAXIMIZE YOUR VAN'S  
STORAGE SPACE AND  
ORGANIZATION WITH  
RANGER DESIGN!**

For the ultimate upfit solution, you can count on Ranger Design to deliver. Engineered for unmatched toughness, our products are built with exceptional craftsmanship and a flawless fit.

The perfect fit for your toughest jobs!



**CONTACT US**

[cs@rangerdesign.com](mailto:cs@rangerdesign.com)

1-800-565-5321

[rangerdesign.com](http://rangerdesign.com)

